

# SERVICE MANUAL



## X1160 Series/X1260 Series X1160Z Series/X1260K Refresh

Date	Revise Version	Description
2007.08.27	V1.0	Initial Issue
2008.07.09	V2.0	Add X1160 Refresh/X1260 Refresh
2008.08.25	V3.0	Add X1160Z/X1160Z Refresh
2008.10.10	V4.0	Add X1260K Refresh

Copyright October.2008. All Rights Reserved P/N: 36.88T03G001

SI: **Suzy**

TSE: **Rock**

Check: *Ahik*

Approved: *Brian*

PARTS	X1160	X1160refresh	X1160Zrefresh	X1160Z	X1260	X1260refresh	X1260Krefresh
LOGO MYLAR	35.88T02G001		35.88T03G001		35.89B02G001		
IO MYLAR	35.88T01G001				35.89B01G001		
THERMAL SWITCH	N/A						43.89T17G001
DMD	48.87K01G001				48.87M01G001		48.89B01G001
SPEAKER	N/A				49.89B01G001		
BLOW-ER1	49.88T01G001						
BLOW-ER2	N/A						49.86E02G001
ZOOM RING	N/A		51.89B04G001		51.89B04G001		
FRONT IR CAP	N/A	51.88T24G001		N/A		51.88T24G001	
FRONT COVER	51.88T03G001	51.88T27G001	75.89B02G001	75.89B01G001		75.89B02G001	
IR SENSOR BD	N/A	80.87Y05G001		N/A		80.87Y05G001	
COLOR WHEEL	70.88T11GR01	70.88T35GR01		70.88T11GR01	70.88T11GR01	70.88T35GR01	
ENGINE	70.88T12GR01	70.88T37GR01	70.88T20GR01		70.89B10GR01	70.89B28GR01	
MAIN BD	70.88T13GR01	70.88T36GR01	70.88T38GR01	70.88T21GR01	70.89B07GR01	70.89B27GR01	70.89B43GR01
LAMP DRIVER	70.88T22GR01	70.88T34GR01		70.88T22GR01	70.88T22GR01	70.88T34GR01	
LVPS	75.88T01G101	75.88T08G001		75.88T01G101		75.88T08G001	75.8BE01G001

## Preface

This manual is applied to X1160 Series/X1260 Series/X1160Z Series/X1260K Refresh projection system. The manual gives you a brief description of basic technical information to help in service and maintain the product.

Your customers will appreciate the quick response time when you immediately identify problems that occur with our products. We expect your customers will appreciate the service that you offer them.

This manual is for technicians and people who have an electronic background. Please send the product back to the distributor for repairing and do not attempt to do anything that is complex or is not mentioned in the troubleshooting.

**Notice:**

*The information found in this manual is subject to change without prior notice. Any subsequent changes made to the data herein will be incorporated in future edition.*

X1160 Series/X1260 Series/X1160Z Series/X1260K Refresh Service Manual

Copyright October.2008

All Rights Reserved

Manual Version 4.0

# Table of Content

## Chapter 1 Introduction

Highlight	1-1
Compatible Mode	1-3
Product Overview	1-5

## Chapter 2 Disassembly Process

Equipment Needed & Product Overview	2-1
Disassemble Lamp Cover Module	2-2
Disassemble Lamp Module	2-2
Disassemble Top Cover Module	2-3
Disassemble Top Shielding	2-4
Disassemble Front Cover Module	2-4
Disassemble Main Board Module & Back Cover Module	2-6
Disassemble Color Wheel Module	2-8
Disassemble Engine Module	2-9
Disassemble DMD Board and DMD Chip	2-10
Disassemble Speaker Module(For X1260 Refresh/X1260 only)	2-11
Disassemble Fan Module	2-12
Disassemble Interrupt Switch Module	2-13
Disassemble Lamp Driver Module	2-14
Disassemble LVPS Module	2-15
Disassemble Bottom Cover Module	2-16
Rod Adjustment	2-17
Re-write Lamp Usage Hour	2-18
Assemble Bottom Cover Module	2-19

Assemble LVPS Module	2-20
Assemble Lamp Driver Module	2-21
Assemble Interrupt Switch Module	2-22
Assemble Fan Module	2-23
Assemble Speaker Module(For X1260 Refresh/X1260 only)	2-24
Assemble DMD Board and DMD Chip	2-25
Assemble Engine Module	2-26
Assemble Color Wheel Module	2-27
Assemble Main Board Module & Back Cover Module	2-28
Assemble Front Cover Module	2-30
Assemble Top Shielding	2-31
Assemble Top Cover Module	2-32
Assemble Lamp Module	2-33

### **Chapter 3 Troubleshooting**

LED Lighting Message	3-1
Main Procedure	3-2
Beep Sound	3-3

### **Chapter 4 Function Test & Alignment Procedure**

Test Equipment Needed	4-1
Service Mode	4-1
OSD Reset	4-1
Test Condition	4-2
Test Inspection Procedure	4-3
PC Mode	4-3
Calibration	4-7
Video Performance	4-9

	Optical Performance Measure	4-11
	Other	4-12
<b>Chapter 5</b>	<b>Firmware Upgrade</b>	
	Equipment Needed	5-1
	DLP Composer Lite Setup Procedure	5-2
	USB Driver Upgrade Procedure	5-4
	Firmware Upgrade Procedure	5-5
	Waveform Download	5-8
<b>Chapter 6</b>	<b>EDID Upgrade</b>	
	EDID Introduction	6-1
	Equipment Needed	6-2
	Setup Procedure	6-3
	EDID Key-In Procedure	6-4
	Default Language Reset	6-5
<b>Appendix A</b>		
	Exploded Overview	I
<b>Appendix B</b>		
	Serial Number System Definition	XXIV
	PCBA Code Definition	XXV
<b>Appendix C</b>		
	RS232 function command summary table	I

# Introduction

## 1-1 Highlight

No	Item	Description
1	Dimensions (LxWxH)	- 267 mm x 187 mm x 80 mm
2	Weight	- <5 lbs
3	Tilt Angle	- 7 degree with elevator mechanism (for X1160/X1260/ X1160Z) - 3 degree with elevator mechanism (for X1160 refresh /X1260 refresh/X1160Z refresh/X1260K refresh)
4	Power Supply	- Universal AC 100 – 240 V ~ 50-60 Hz with PFC input - 160W for Osram E20.6 Lamp @ normal operation (for x1160 series/x1260 series/x1160z series) - 180W for Osram E20.6 Lamp @ normal operation (only for x1260k refresh) - Variant FAN speed control (Depends on temperature variance)
5	Keystone correction	- +/- 40 degree (80 degree)
6	Cooling system	- Advanced Air Flow - One fan with system acoustic noise level 36 dB(A) (typical) - Temperature control circuits with adaptive fan rotational speeds - Maximum touch temperature follow UL60950-1
7	Brightness	Engineering Spec: - 1700 ANSI Lumens (Typical) (for X1160/X1260/X1160Z) - 1445 ANSI Lumens (Minimum) (for X1160/X1260/X1160Z) - 1800 ANSI Lumens (Typical) ( for X1160 refresh/X1260 refresh/X1160Z refresh/X1260K refresh) - 1600 ANSI Lumens (Minimum) (for X1160 refresh /X1260 refresh/X1160Z refresh/X1260K refresh) Marketing Spec: - 2000 ANSI Lumens

No	Item	Description
8	Contrast	<p>Engineering Spec:</p> <ul style="list-style-type: none"> <li>- 1500 : 1 Full White and Black (Minimum; Full power mode) (for X1160/X1260/X1160Z)</li> <li>- 1800 : 1 Full White and Black (Typical; Full power mode) (for X1160/X1260/X1160Z)</li> <li>- 1400 : 1 Full White and Black (Minimum; Full power mode) (for X1160 refresh/X1260 refresh/X1160Z refresh)</li> <li>- 1800 : 1 Full White and Black (Typical; Full power mode) (for X1160 refresh/X1260 refresh/X1160Z refresh)</li> <li>- 400 : 1 Full White and Black (Minimum; Full power mode)</li> <li>- 600 : 1 Full White and Black (Typical; Full power mode) (only for X1260K refresh)</li> </ul> <p>Marketing Spec:</p> <ul style="list-style-type: none"> <li>- 2000:1</li> </ul>
9	Uniformity	<p>Engineering Spec:</p> <ul style="list-style-type: none"> <li>- 65% Japan standard (Minimum; Full power mode)</li> <li>- 80% Japan standard (Typical; Full power mode)</li> </ul> <p>Marketing Spec:</p> <ul style="list-style-type: none"> <li>- 85%</li> </ul>
10	Throw ratio	<ul style="list-style-type: none"> <li>- 1.95:1 distance/width @60" (For X1160 refresh /X1160)</li> <li>- 1.95 – 2.15:1 distance/width @60" (For X1260 refresh / X1260/X1160Z/X1160Z refresh/X1260K refresh)</li> </ul>
11	Lamp door protection	<ul style="list-style-type: none"> <li>- Lamp Power Supply shut off automatically when lamp cover open</li> </ul>
12	Projection lens	<ul style="list-style-type: none"> <li>- F# 2.41 ,f = 21.79mm, Fix lens (For X1160 refresh /X1160)</li> <li>- F# 2.41~2.55, f = 21.79~23.99 mm, 1.10X Mechanical Zoom Lens (For X1260 refresh/X1260/X1160Z/X1160Z refresh/X1260K refresh)</li> </ul>
13	Lamp life	<ul style="list-style-type: none"> <li>- 3500 hours min, 50% survival rate</li> </ul>
14	System controller	<ul style="list-style-type: none"> <li>- TI DDP2230</li> </ul>
15	Terminal	<p>For X1160 refresh/X1160</p> <ul style="list-style-type: none"> <li>- One D-sub VGA input</li> <li>- One Composite input</li> <li>- One S-Video input(4 pin Mini din)</li> <li>- One USB port (Type B Female)</li> </ul> <p>For X1260 refresh/X1260/X1260K refresh</p> <ul style="list-style-type: none"> <li>- One D-sub VGA input</li> <li>- One D-sub VGA output</li> <li>- One Composite input</li> <li>- One S-Video input(4 pin Mini din)</li> <li>- One audio input (2.5m phone jack)</li> <li>- One USB port (Type B Female)</li> <li>- One RS-232 (3 pin Mini din)</li> </ul>



No	Item	Description
16	Number of active dots	<ul style="list-style-type: none"> <li>- Number of active dots : 800(H) x 600(V) (for X1160/X1160 refresh/1160Z/X1160Z refresh)</li> <li>- Number of active dots : 1024(H) x 768(V) (for X1260/X1260 refresh/X1260K refresh)</li> </ul>
17	Input signal spec.	<ul style="list-style-type: none"> <li>- Hsync Frequency 31 ~ 69 kHz (for X1160 refresh/X1160/X1160Z/X1160Z refresh)</li> <li>- Hsync Frequency 31 ~ 80 kHz (for X1260 refresh/X1260K refresh)</li> <li>- Vsync Frequency 50 ~ 85 Hz</li> <li>- Video Signal RGB (PC) <ul style="list-style-type: none"> <li>● Analog RGB 0.7Vp-p, 75 ohm, Separate TTL H,V Sync</li> <li>● Analog RGB 1Vp-p, 75 ohm, Sync. On Green signal</li> <li>● Analog RGB 0.7Vp-p, 75 ohm, Composite TTL Sync</li> </ul> </li> <li>- Video <ul style="list-style-type: none"> <li>● Composite video 1Vp-p,75 ohm</li> <li>● S-video Luminance 0.714Vp-p, 75 ohm,Chrominance 0.286Vp-p, 75 ohm</li> <li>● Component Video 1Vp-p, 75 ohm</li> </ul> </li> </ul>
18	TI DMD	<ul style="list-style-type: none"> <li>- TI DMD 0.55" 12° 2xLVDS Type-X SVGA Digital Mirror Device (for X1160/X1160 refresh/X1160Z/X1160Z refresh)</li> <li>- TI DMD 0.55" 12° 2xLVDS Type-X XGA Digital Mirror Device (for X1260 refresh/X1260/X1260K refresh)</li> </ul>
19	Video compatibility	<ul style="list-style-type: none"> <li>- Standards : <ul style="list-style-type: none"> <li>● NTSC (3.58/4.43)</li> <li>● PAL (B/D/G/H/I/M/N)</li> <li>● SECAM (B/D/G/K/K1/L)</li> </ul> </li> <li>● HDTV - 480i, 576i, 480p, 576p, 720p, 1080i</li> </ul>
20	Power consumption	<ul style="list-style-type: none"> <li>- 225W Max</li> <li>- Standby &lt; 8W at AC 110V (for X1160/X1260/X1160Z)</li> <li>- Standby &lt; 5W at AC 110V (for X1160 refresh/X1260 refresh/X1160Z refresh)</li> <li>- 250W Max.</li> <li>- Standby &lt; 5W at AC 110V (only for X1260K refresh)</li> </ul>
21	Color wheel	<ul style="list-style-type: none"> <li>- 6 segments (R90/Y28/G90/C28/W42/B82)</li> <li>- 7200 rpm</li> <li>- 9000 rpm @ CW 3X, PAL 50Hz (for X1160 refresh/X1260 refresh/X1160Z refresh/X1260K refresh)</li> </ul>
22	Lamp	<ul style="list-style-type: none"> <li>- 160 Watt OSRAM (for X1160 Series/X1260 Series/X1160Z Series)</li> <li>- 180 Watt OSRAM (only for X1260K refresh)</li> </ul>
23	Temperature	<ul style="list-style-type: none"> <li>- Operating: 5°C -- 35°C</li> <li>- Storage: -20°C -- 60°C</li> </ul>

## 1-2 Compatible Mode

### VGA Analog - PC Signal

Compatibility	Resolution	V-Sync [Hz]	H-Sync [KHz]
VGA	640x480	60	31.50
	640x480	72	37.90
	640x480	75	37.50
	640x480	85	43.30
	720x400	70	31.50
	720x400	85	37.90
SVGA	800x600	56	35.10
	800x600	60	37.90
	800x600	72	48.10
	800x600	75	46.90
	800x600	85	53.70
	832x624	75	49.70
XGA	1024x768	60	48.40
	1024x768	70	56.50
	1024x768	75	60.00
	1024x768	85	68.70
SXGA	1152x864	70	63.80
	1152x864	75	67.50
	1280x1024	60	64.00
	1152x864 (For X1260/X1260 re- fresh/X1260K refresh)	85	77.10
	1280x1024 (For X1260/X1260 re- fresh/X1260K refresh)	72	77.00
	1280x1024 (For X1260/X1260 re- fresh/X1260K refresh)	75	80.00
QuadVGA	1280x960	60	60.00
	1280x960 (For X1260/X1260 re- fresh/X1260K refresh)	75	75.20

### VGA Analog - Extended Wide timing

Compatibility	Resolution	V-Sync [Hz]	H-Sync [KHz]
WXGA	1280x768	60	48.36
	1280x768	75	60.30
	1280x720	60	44.80
	1280x768 (For X1260/X1260 re- fresh/X1260K refresh)	85	68.60
	1280x800	60	49.60
	1440x900	60	59.90

# Product Overview

## Projector Outlook

### Front /Upper side

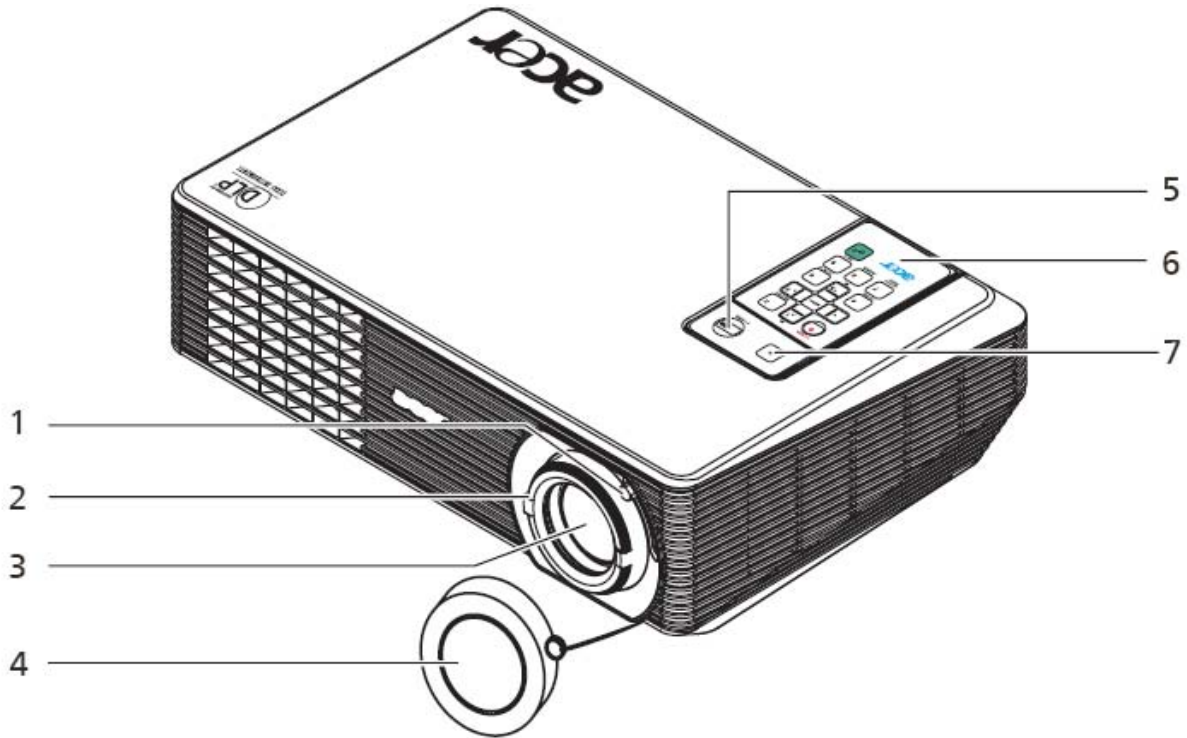

Item	Description	Item	Description
1	Zoom ring (X1260 series/ X1260K Refresh)	5	Power button and Power Indicator LED
2	Focus ring	6	Remote controller
3	Zoom lens	7	Remote control receiver
4	Lens cap		

## Rear side

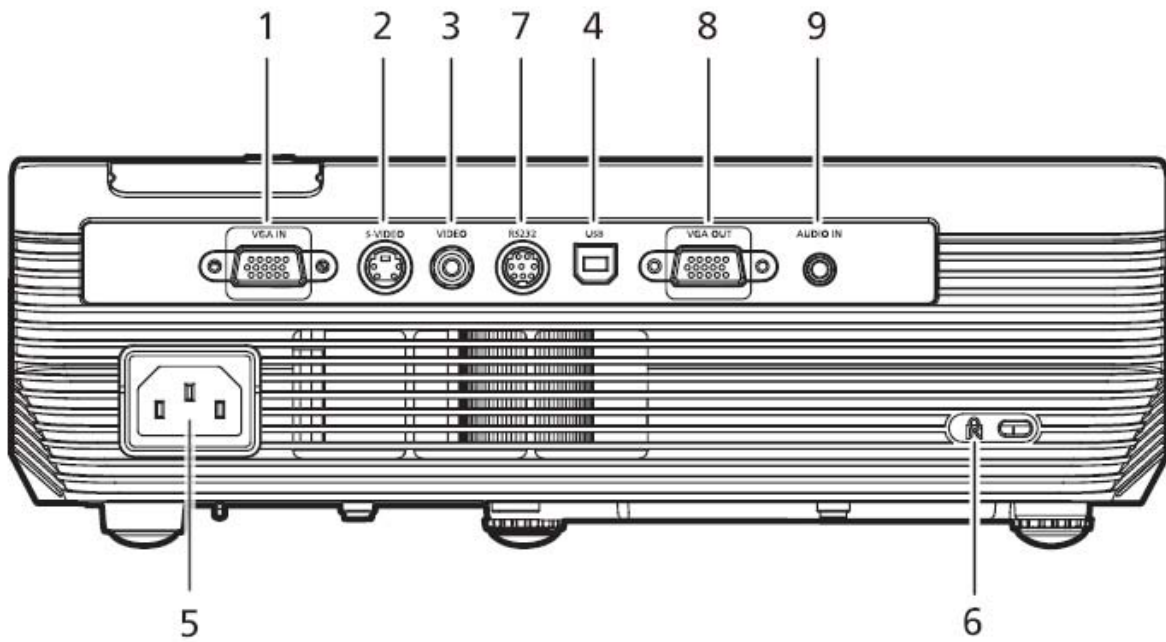

Item	Description	Item	Description
1	PC analog signal/HDTV/component video input connector	6	Kensington™ lock port
2	S-Video input connector	7	RS232 connector (Only for X1260 refresh/X1260/X1260K refresh)
3	Composite video input connector	8	Monitor loop-through output connector (VGA-Out) (Only for X1260 refresh/X1260/X1260K refresh)
4	USB connector	9	Audio input connector (Only for X1260 refresh/X1260/X1260K refresh)
5	Power socket		

## Remote Control and Control Panel Layout

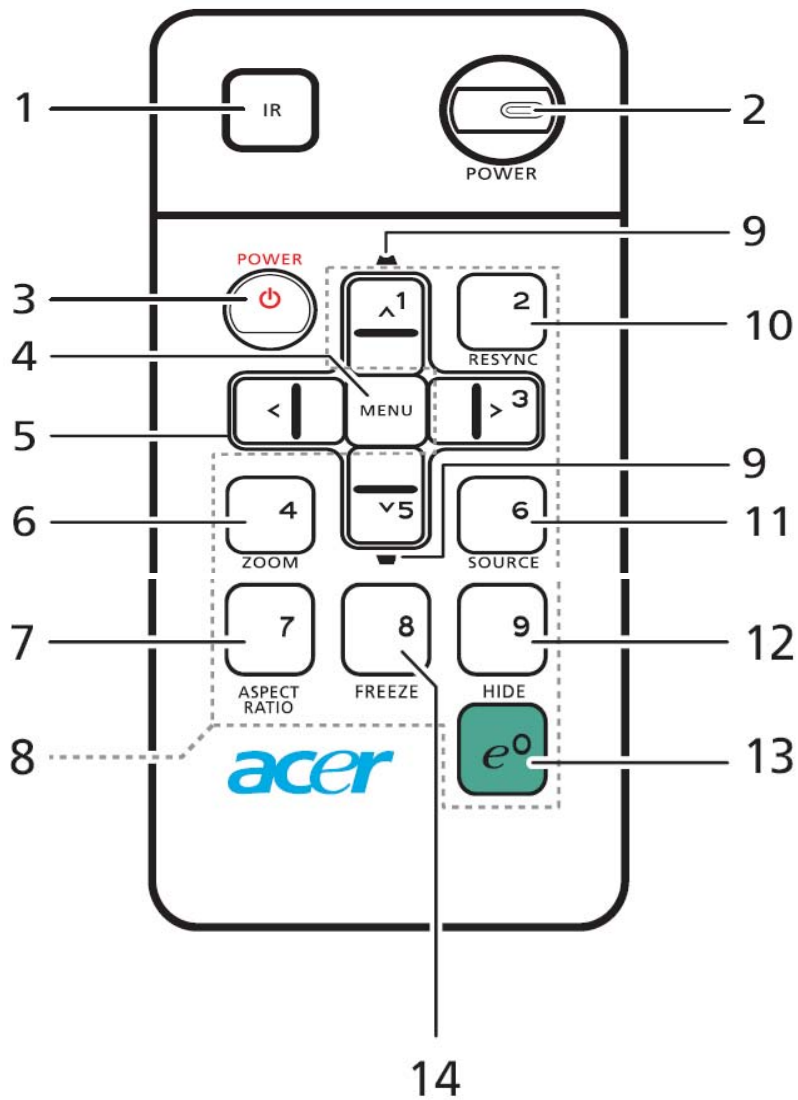

Item	Icon	Function	Description
1		Infrared transmitter	Sends signals to the projector.
2		Power/Power LED	Power button and Power Indicator LED.
3		POWER	Refer to the “Turning the Projector On/Off” section.
4		MENU	<ul style="list-style-type: none"> <li>Press “MENU” to launch the Onscreen display (OSD) menu, back to the previous step for the OSD menu operation or exit the OSD menu.</li> <li>Confirm your selection of items.</li> </ul>
5		Four directional select keys	Use up, down, left, right buttons to select items or make adjustments to your selection.
6		ZOOM	Zooms the projector display in or out.
7		ASPECT RATIO	To choose the desired aspect ratio (Auto/4:3/16:9).
8		Keypad 0~9	Press “0~9” to input a password in the “Security settings”.
9		KEYSTONE	Adjusts the image to compensate for distortion caused by tilting the projector ( $\pm 40$ degrees).

Item	Icon	Function	Description
10		RESYNC	Automatically synchronizes the projector to the input source.
11		SOURCE	Press "SOURCE" to choose RGB, Component, S-Video, Composite and HDTV sources.
12		HIDE	Momentarily turns off the video. Press "HIDE" to hide the image, press again to display the image.
13		Empowering key	Unique Acer functions: eView, eTimer Management.
14		FREEZE	To pause the screen image.

Note:



## Connecting the Projector

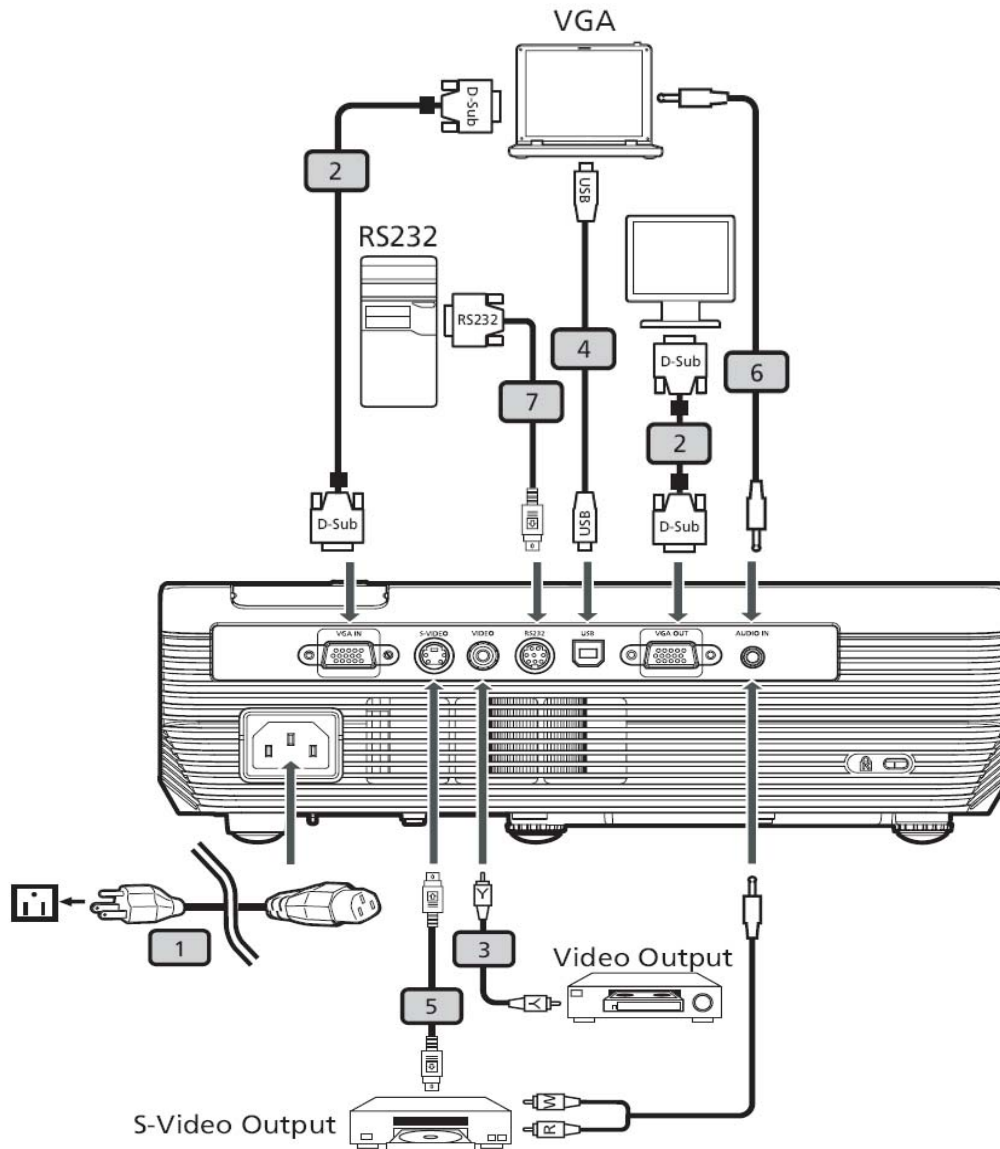

Item	Description	Item	Description
1	Power cord	5	S-Video cable
2	VGA cable	6	Audio cable jack/jack
3	Composite video cable	7	RS232 cable
4	USB cable		



*Note: To ensure the projector works well with your computer, please make sure the timing of the display mode is compatible with the projector.*



# X1160 Refresh/X1160/X1160Z Refresh/X1160Z

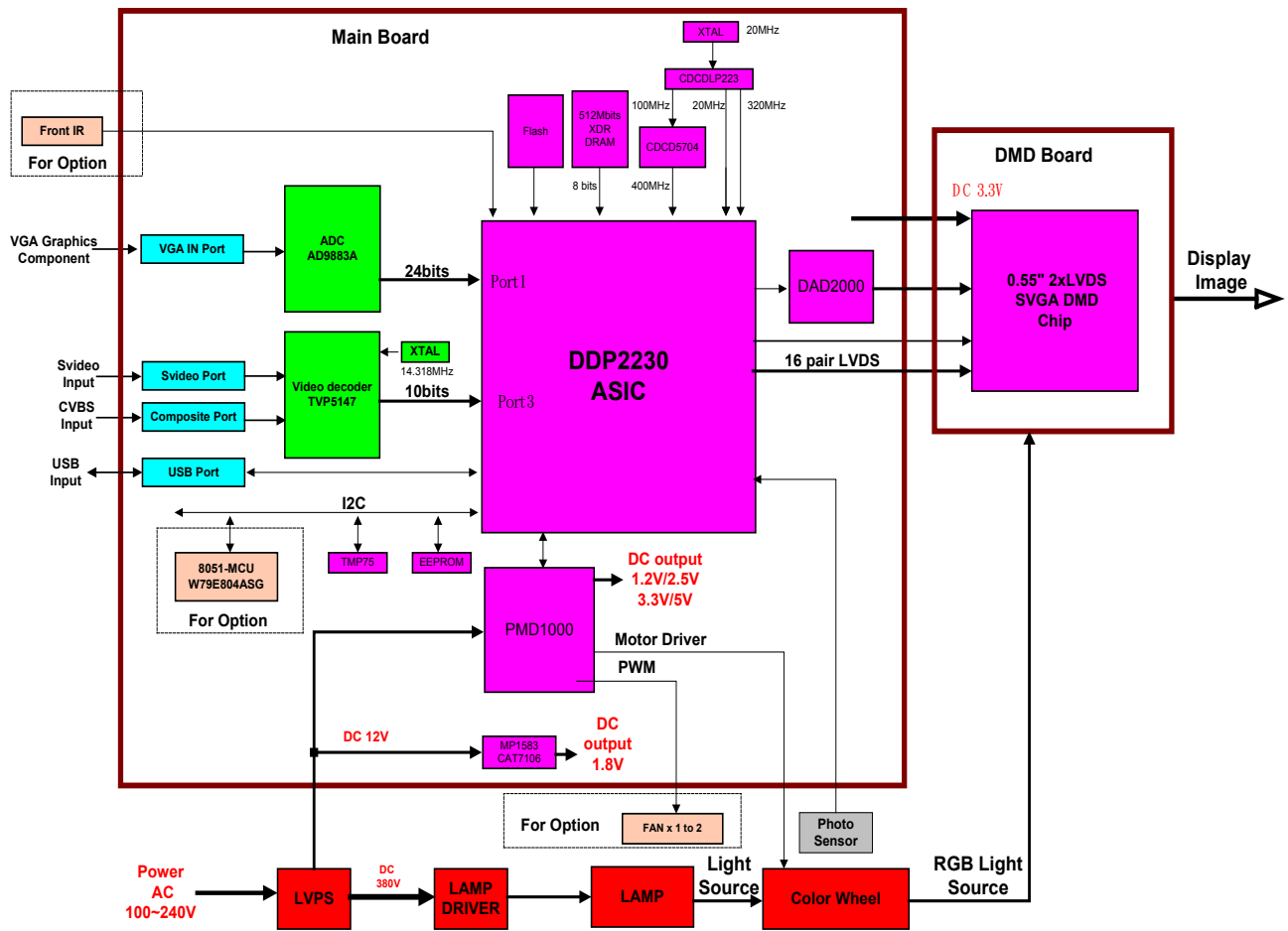

# X1260 Refresh/X1260/X1260K Refresh

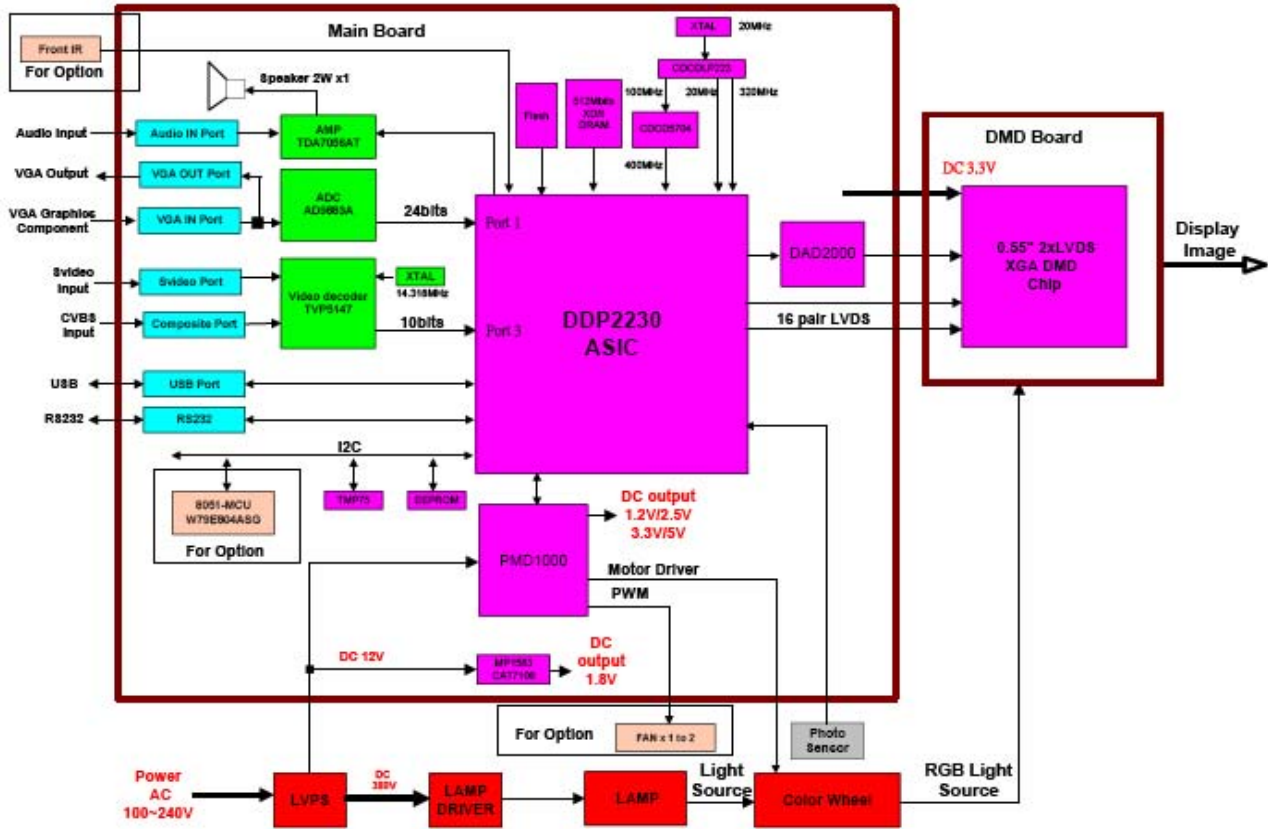

## Bottom Cover Dimension

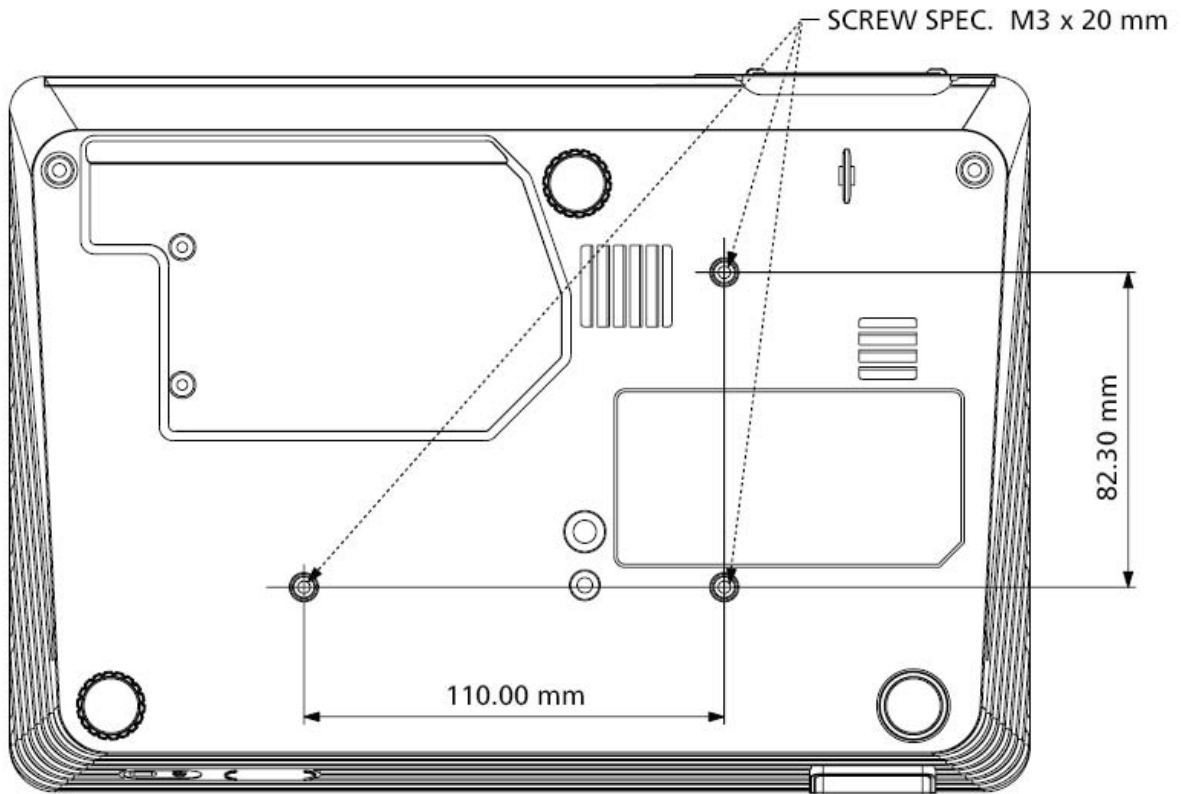

---

# Disassembly & Assembly Process

---

## 2-1 Equipment Needed & Product Overview

1. Screw Bit (+) :107
2. Hex Sleeves 5mm
3. Screw Bit (+) :102
4. Screw Bit (-) :102
5. Long Nose Nipper
6. Tweezers
7. X1160/X1160 refresh/X1260/X1260 refresh/X1160Z/X1160Z refresh/X1260K refresh unit

\* *Before you start: This process is protective level II. Operators should wear electrostatic chains.*

\* *Note: 1.If you need to replace the main board, you have to get into service mode and record the lamp usage hour. please refer to section 2-18.*

*2.The disassembly and assembly process for X1160 Series/X1260 Series/X1160Z Series/X1260K Refresh is the same. Here, we take X1160/X1260 as example.*



## 2-2 Disassemble Lamp Cover Module

1. Unscrew 2 screws on the lamp cover module



*Lamp Cover Module*

## 2-3 Disassemble Lamp Module

1. Unscrew 2 screws on the lamp module

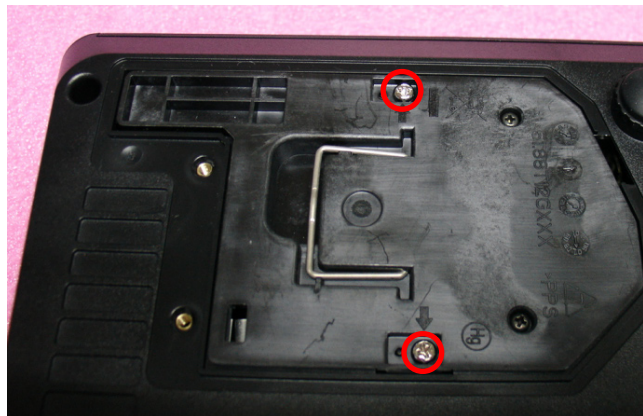

*Lamp Module*

## 2-4 Disassemble Top Cover Module

1. Unscrew 2 screws on the unit base
2. Use the tweezers to scratch sharply on the both side

*Note: You'd better drop out two tenons in the back side before disassemble the top cover module. (As the red square) And then the rest of the two tenons will be spontaneously fall. (As the green square)*

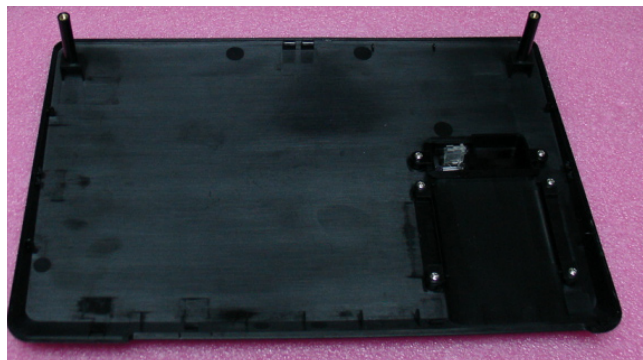
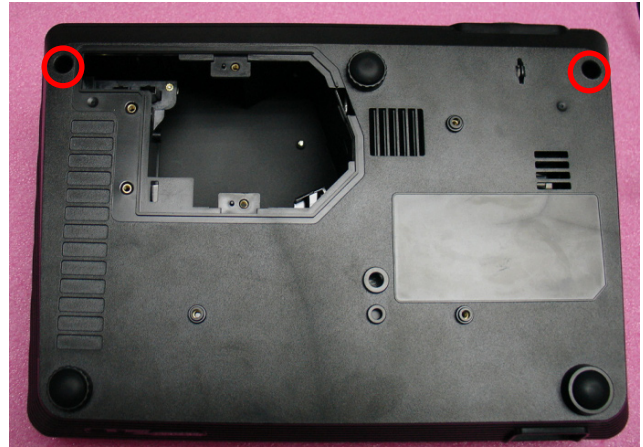

Top Cover Module

## 2-5 Disassemble Top Shielding

1. Unscrew 7 screws on the top shielding



## 2-6 Disassemble Front Cover Module

1. Unscrew 1 screw on front cover module  
(Only for X1260/X1260 Refresh/X1260 Refresh)
2. Press four tenons to disassemble the front cover module
  - First, disassemble right side of front cover: Push the top side of bottom cover to right and push the top side of the front cover to front, then one tenon will be out. Push the front cover to above, then another tenon will be out.

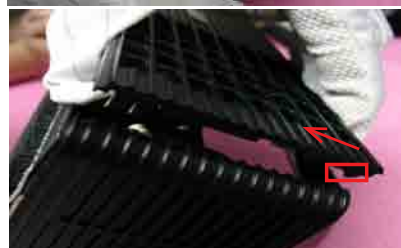

- Then, the left side of the front cover is the same as the right side

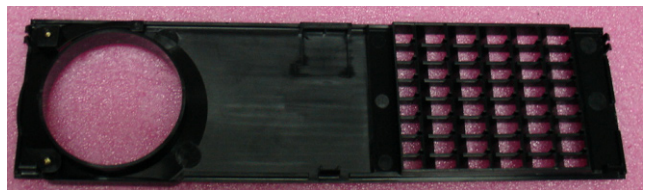

*Front Cover Module*

*Note: Avoid touch the lens when disassemble the front cover.*





## 2-7 Disassemble Main Board Module & Back Cover Module

1. Unscrew 3 screws and 5 connectors on main board module & back cover module(X1160/X1160 Refresh/X1160Z/X1160Z refresh)

Unscrew 3 screws and 6 connectors on main board module & back cover module(X1260/X1260 Refresh/X1260K Refresh)



For (X1160/X1160 Refresh/X1160Z/X1160Z refresh)

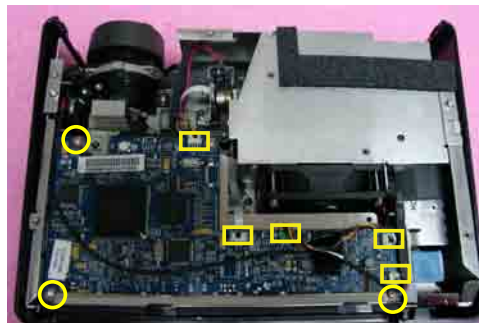

For X1260/X1260 Refresh/X1260K Refresh

*Note: Speaker Cable(only for X1260/X1260 Refresh/X1260K Refresh)& Fan Cable must be fixed on Main Board by film tape to avoid to stretch into the Fan.*



Main Board Module&Back Cover Module

2. Unscrew 1 screw on main board module & back cover module

*Note: Use the Long Nose Nipper to lock the hex screw nut.*

3. Unscrew 2(4 for X1260/X1260 Refresh/ X1260K Refresh) hex screws on main board module & back cover module

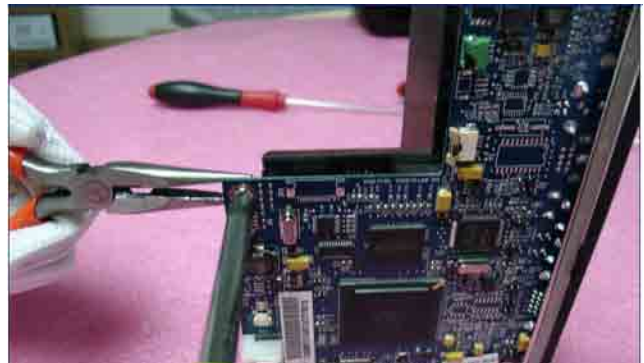

For (X1160/X1160 Refresh/X1160Z/ X1160Z refresh)



For (X1260/X1260 Refresh/X1260K Refresh)



Main Board Module



Back Cover Module

## 2-8 Disassemble Color Wheel Module

1. Unscrew 1 screw on mylar
2. Unscrew 2 screws on color wheel module

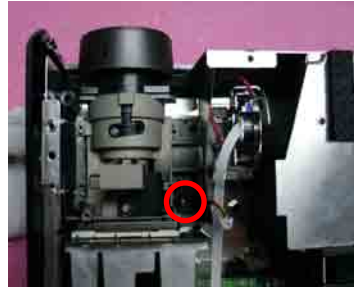

*Mylar*

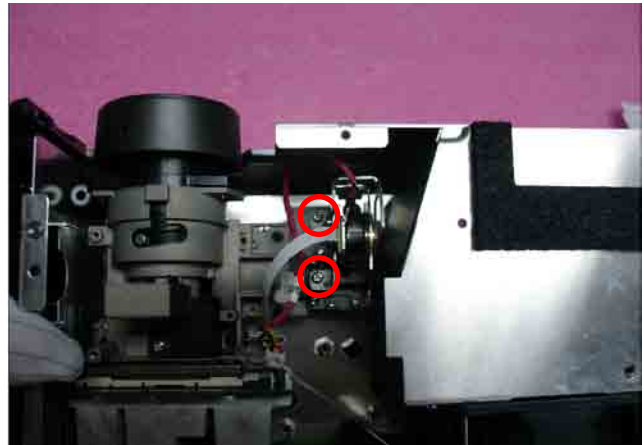

3. Unscrew 1 screw on photo sensor

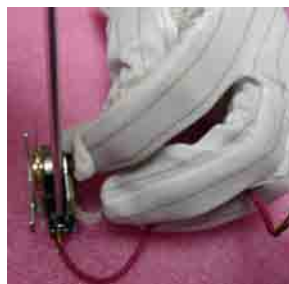

## 2-9 Disassemble Engine Module

1. Unscrew 4 screws on engine module
2. Unscrew 2 screws on engine module to disassemble the zoom ring and zoom ring holder(X1260/X1260 Refresh/X1260K Refresh only)
3. Unscrew 3 screws on focus ring

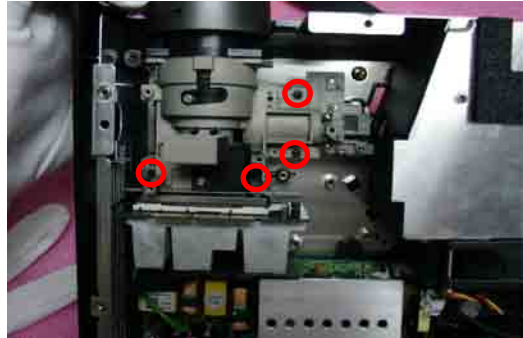

*Engine Module*



*For (X1260/  
X1260 Refresh/  
X1260K Refresh)*



*Zoom Ring Holder and Zoom Ring For (X1260/X1260 Refresh/X1260K Refresh)*



*Focus Ring*

## 2-10 Disassemble DMD Board and DMD Chip

1. Unscrew 2 screws on engine module, disassemble Heat Sink and DMD Board&DMD chip module
2. Unlock the lockhole by Screw Bit(-) to disassemble the DMD chip from the DMD board

*Note:It will be unlocked if the Screw Bit(-) turn reverse. Contrary,It will be locked.*

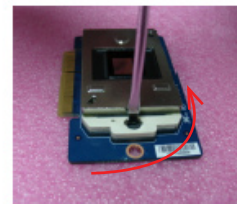
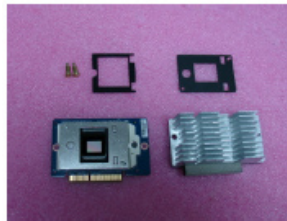
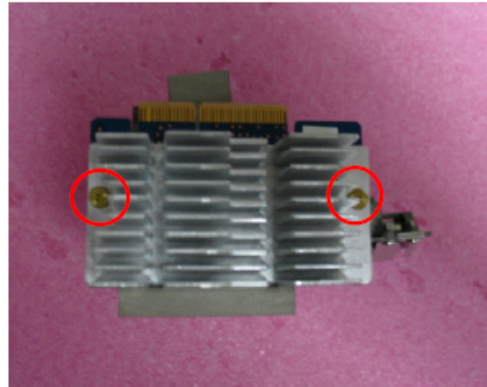

## 2-11 Disassemble Speaker Module(For X1260/ X1260 Refresh/X1260K Refresh)

1. Unscrew 1 screw and press 2 tenons to disassemble Speaker Module

*- Press the plastic of the speaker Holder and then use the tweezers to press the tenon.*

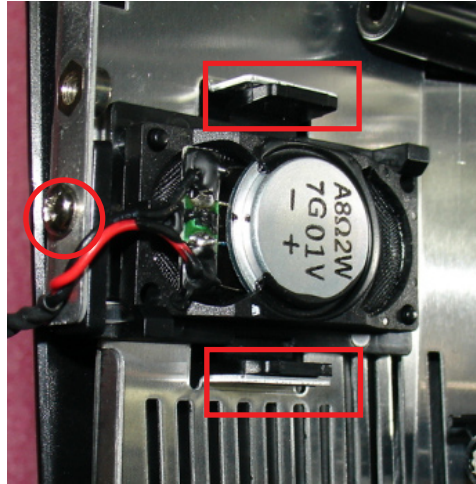

2. Press two tenons to disassemble the speaker from the speaker holder

*Note: Avoid to press the speaker with great strength.*



Speaker holder&Speaker



## 2-12 Disassemble Fan Module

1. Unscrew 4 screws on the fan module

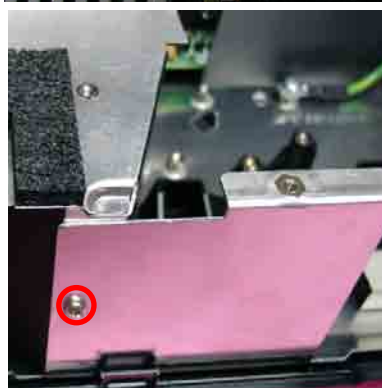
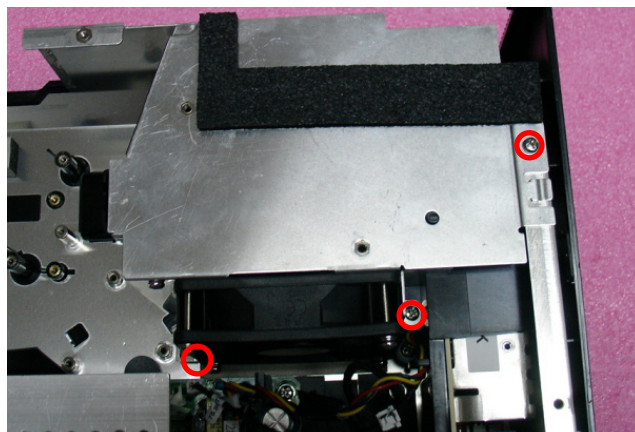

*Note: The fan cable pass through from the aperture.*

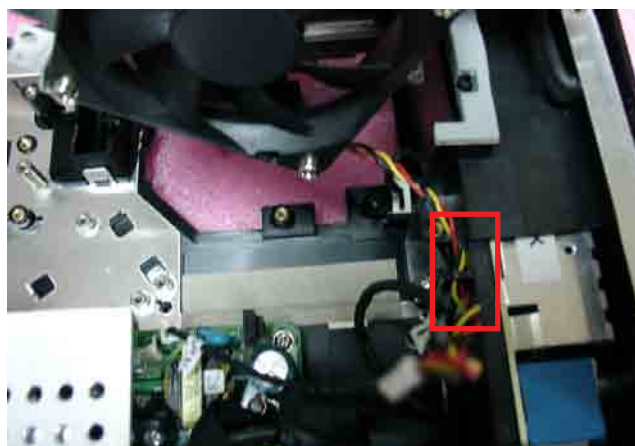

## 2-13 Disassemble Interrupt Switch Module

1. Unplug 1 connector and unscrew 1 screw and disassemble 1 film tape to disassemble interrupt switch module

*Note: Interrupt switch cable must be pass through a dent and a aperture. And use a film tape to fix the cable in the dent.*

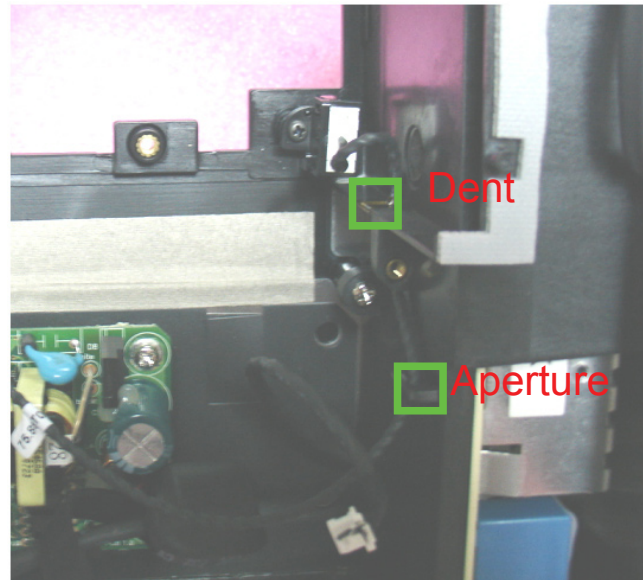
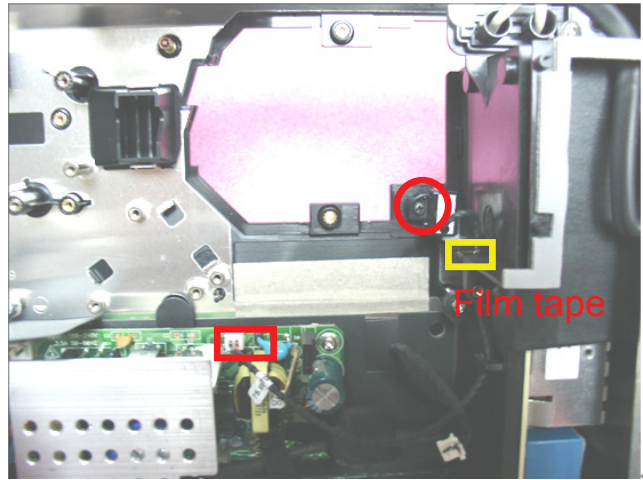

2. Disassemble interrupt switch from interrupt switch holder

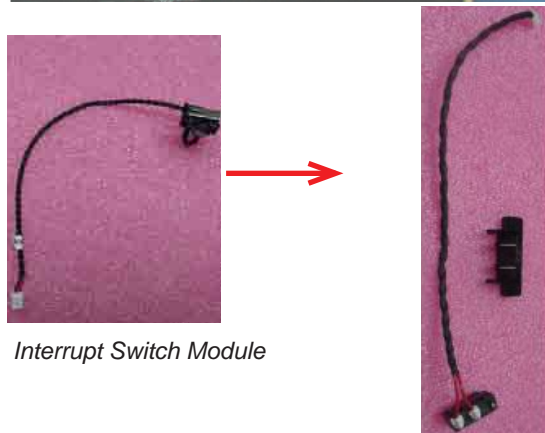

*Interrupt Switch Module*

*Interrupt Switch&holder*



## 2-14 Disassemble Lamp Driver Module

1. Unplug 1 connector and unscrew 1 screw on lamp driver module
2. Unplug 1 connector and unscrew 2 screws on lamp driver to lamp cable

*Note: The lamp driver to lamp cable must be pass through two Dents.(As the yellow square)*

3. Unplug 2 connectors to disassemble 3PIN and 5PIN cable

*Note:The 3 PIN and 5 PIN cable must be pass through a Dent.(As the yellow square)*

4. Unscrew 4 screws on lamp driver module

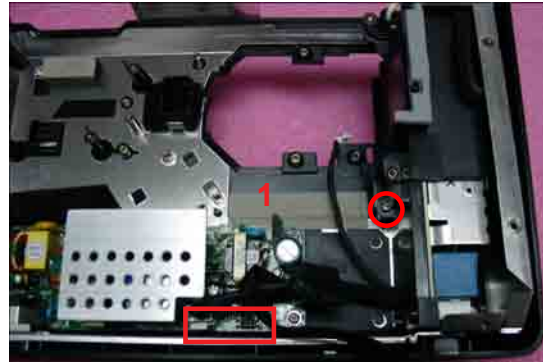

Lamp Driver to Lamp Cable

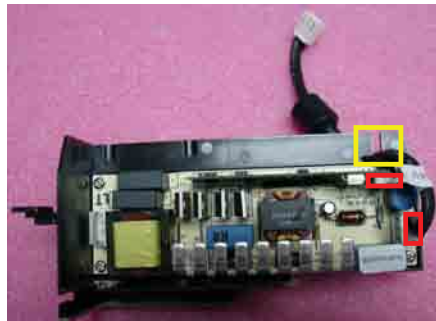

3



3 PIN&5 PIN Cable



4



Lamp Driver Holder

Lamp Driver Module

## 2-15 Disassemble LVPS Module

1. Unscrew 1 ground screw(As red circle)
2. Unscrew 1 screw on LVPS module(As yellow circle)
3. Disassemble LVPS BRKT
4. Unscrew 3 screws on LVPS module(As green circle)

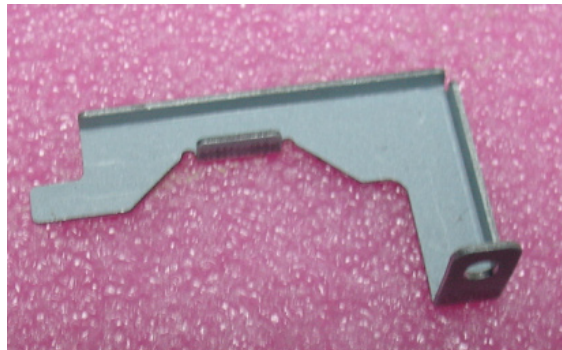
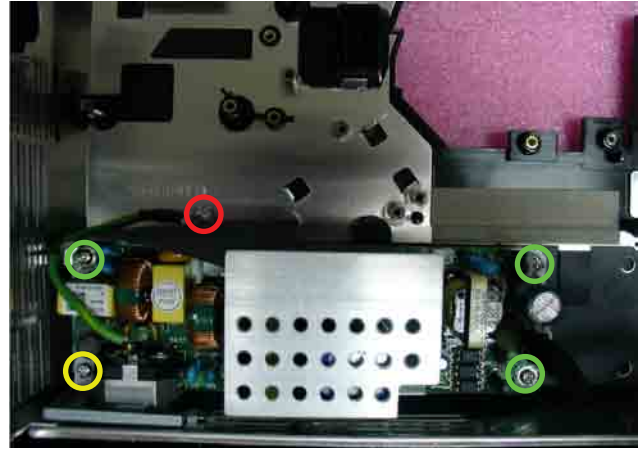

*LVPS BRKT*



*LVPS Module*

## 2-16 Disassemble Bottom Cover Module

1. Unscrew 1 screw on bottom cover module
2. Disassemble 1 EMI tape
3. Disassemble the bottom cover shielding from bottom cover module
4. Press two tenons to disassemble the ROD DUCT
  - Pull aside the iron sheet with Tweezers to disassemble the ROD DUCT

*Note: Due to the iron sheet was out of shape, so we must turn it back before assemble the ROD DUCT.*



ROD DUCT



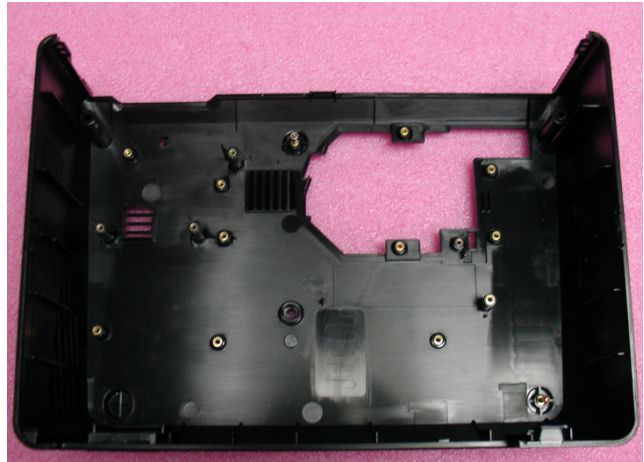

*Bottom Cover Module*

## 2-17 Rod Adjustment

### 1. environment adjustment

- The distance between the engine and the screen is 1.7 M
- This process should be done at a dark environment. (under 5 Lux)

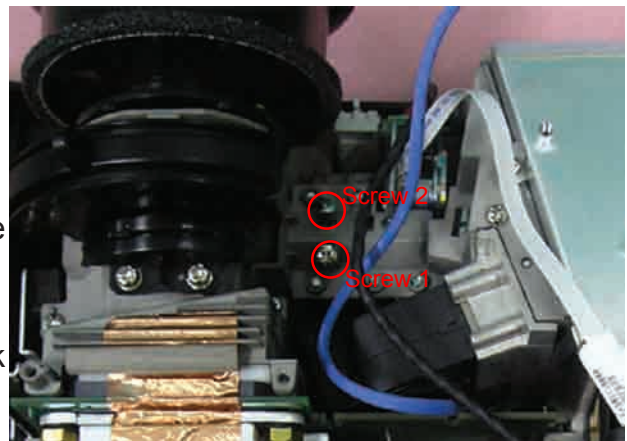

### 2. Procedure adjustment

- Change the screen to “white screen.”
- Adjust the screws by using the rod on the engine module to readjust the image. (adjust until the yellowish or bluish parts disappeared.)

### 3. Abnormal image inspection

- It should not have any abnormal color at the rim of the image by estimating through the eyes.

*Note: To avoid over adjust the rod. After the operation, please use the glue to fixed the screws.*

## 2-18 Re-write Lamp Usage Hour

*- Take X1260 for example, X1160/X1160 Refresh/X1260 Refresh/X1160Z/X1160Z Refresh/X1260K Refresh is the same as X1260*

1. Get into service mode.
  - press (power > left > left > menu) to get into service mode.
2. Use left or right key to re-write the lamp hour back to previous lamp usage hour.
3. Choose exit

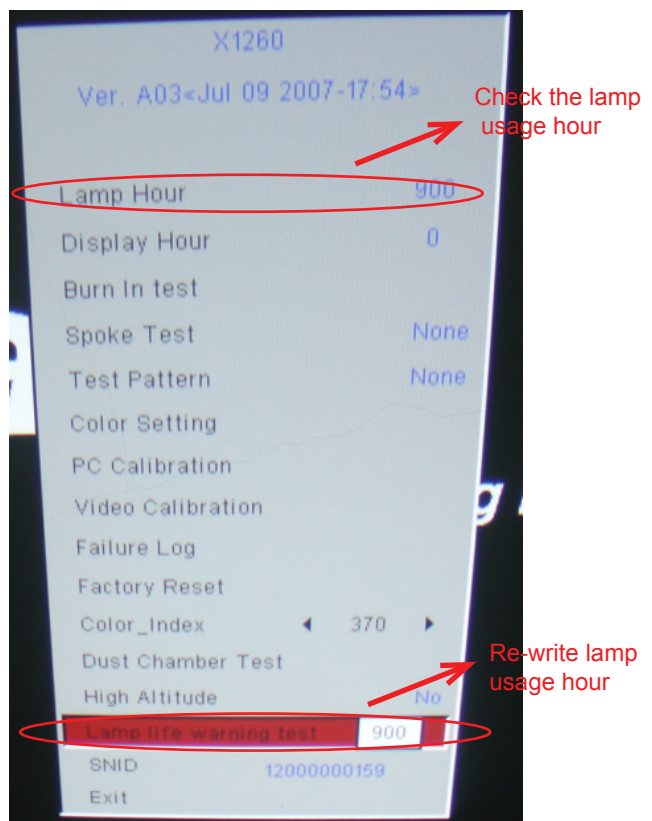

## 2-19 Assemble Bottom Cover Module

1. Fasten two tenons to assemble ROD DUCT
2. Assemble the bottom cover shielding on bottom cover module
3. Stick 1 EMI tape
4. Screw 1 screw on bottom cover module



*ROD DUCT*



*Bottom Cover shielding*



*Bottom Cover Module*



## 2-20 Assemble LVPS Module

1. Screw 3 screws on LVPS module(As green circle)
2. Screw 1 screw to assemble LVPS BRKT (As yellow circle)
3. Screw 1 ground screw(As red circle)

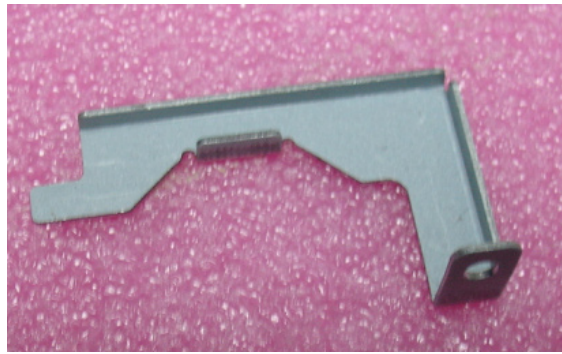

LVPS BRKT



LVPS Module

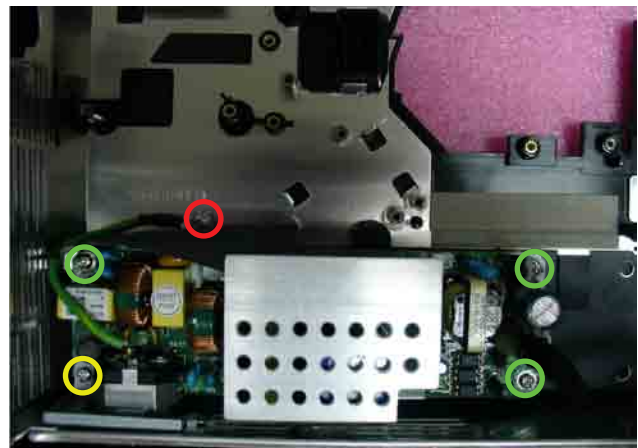

## 2-21 Assemble Lamp Driver Module

1. Screw 4 screws to assemble lamp driver module on lamp driver holder



Lamp Driver Holder

Lamp Driver Module

2. Plug 2 connectors to assemble 3PIN and 5PIN cable



3 PIN&5 PIN Cable

*Note: The 3 PIN and 5 PIN cable must be pass through a Dent. (As the yellow square)*

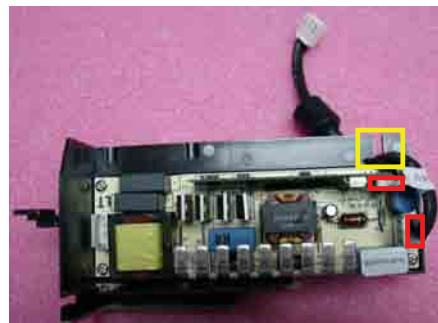

2

3. Plug 1 connector and screw 2 screws to assemble lamp driver to lamp cable



Lamp Driver to Lamp Cable

*Note: The lamp driver to lamp cable must be pass through two Dents. (As the yellow square)*



3

4. Plug 1 connector and screw 1 screw on lamp driver module

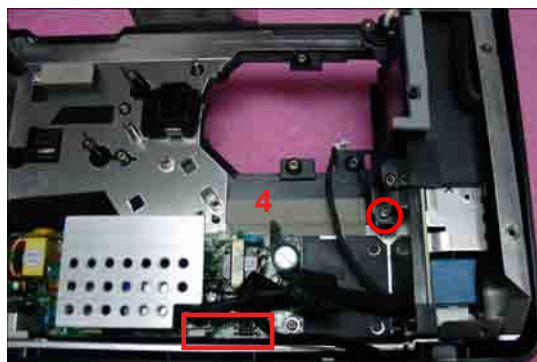

4



## 2-22 Assemble Interrupt Switch Module

1. Plug 1 connector and screw 1 screw and stick 1 film tape on interrupt switch module

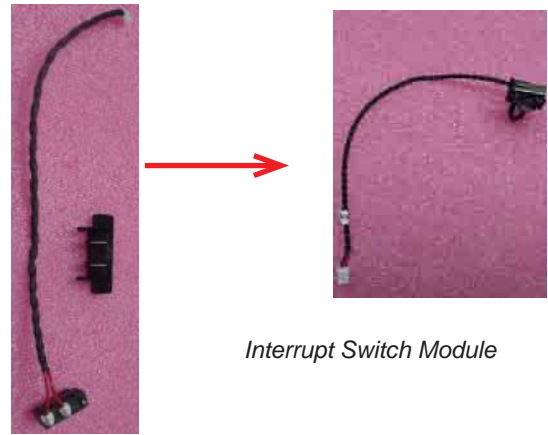

Interrupt Switch&holder

*Note: Interrupt switch cable must be pass through a dent and a aperture. And use a film tape to fix the cable in the dent.*

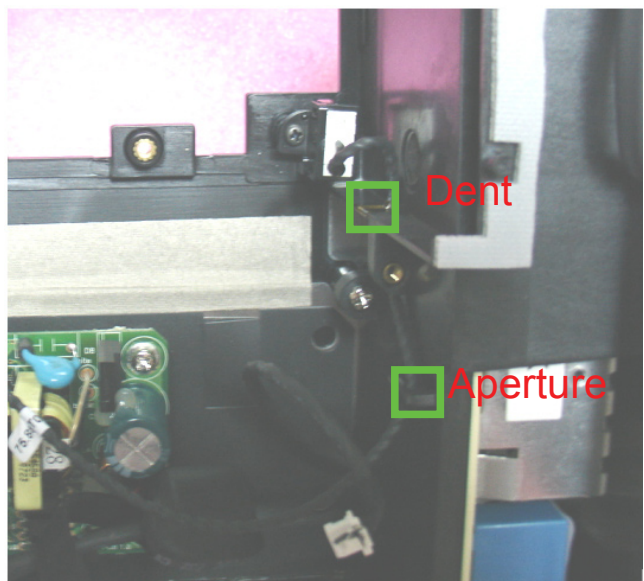
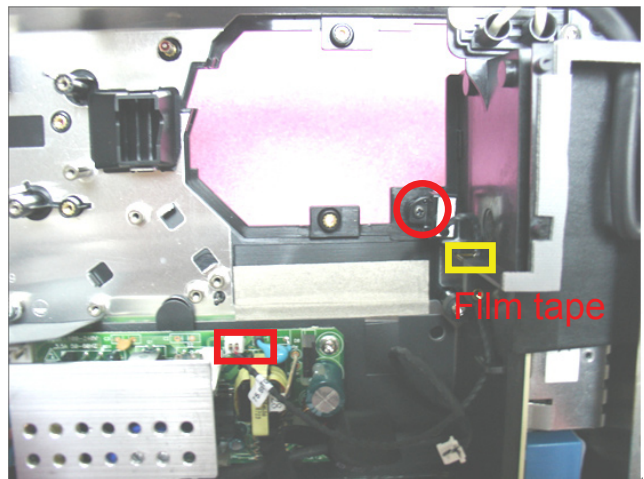

# 2-23 Assemble Fan Module

1. Screw 4 screws to assemble the fan module

*Note: The fan cable pass through from the aperture.*

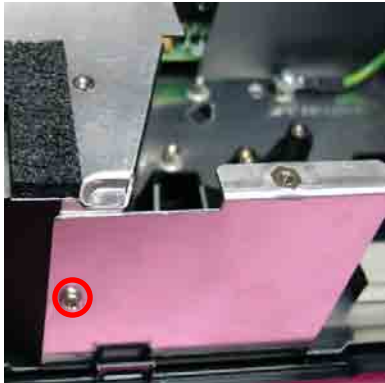
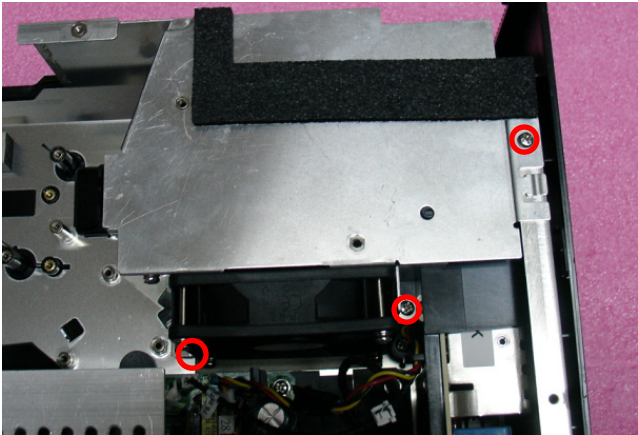

## 2-24 Assemble Speaker Module(For X1260 only)

1. Fasten two tenons to assemble the speaker on the speaker holder

*Note: Avoid to press the speaker with great strength.*

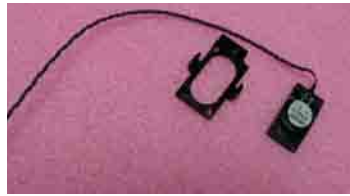

Speaker holder&Speaker



2. Fasten 2 tenons(as the red square) and screw 1 (as red circle) screw to assemble Speaker Module

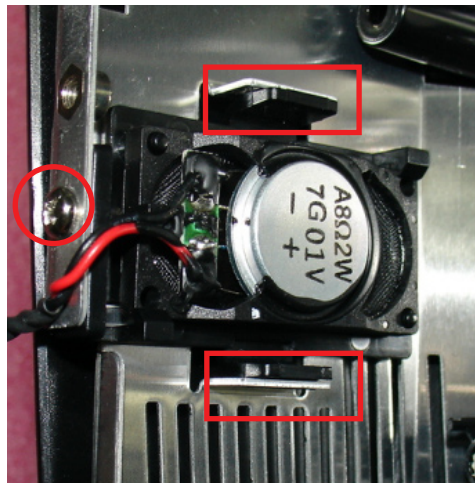

## 2-25 Assemble DMD Board and DMD Chip

1. Lock the lockhole by Screw Bit(-) to assemble the DMD board on the DMD chip

*Note:It will be locked if the Screw Bit(-) turn obverse.*

2. Assemble all components of DMD parts.
3. Screw 2 screws on engine module, assemble Heat Sink and DMD Board&DMD chip module

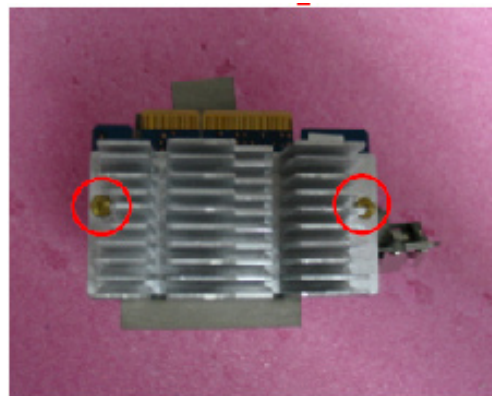
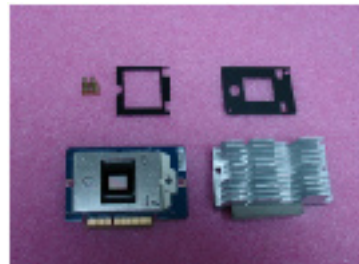
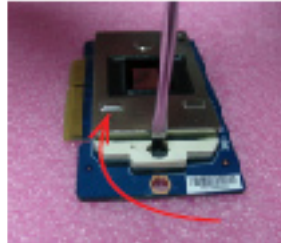

## 2-26 Assemble Engine Module

1. Screw 3 screws on focus ring
2. Screw 2 screws on engine module to assemble the zoom ring and zoom ring holder(For (X1260/X1260 Refresh/ X1260K Refresh)



*Focus Ring*



*Zoom Ring Holder and Zoom Ring For (X1260/X1260 Refresh/X1260K Refresh)*



*For (X1260/X1260 Refresh/ X1260K Refresh)*



*Engine Module*

2. Screw 4 screws to assemble the engine module



## 2-27 Assemble Color Wheel Module

1. Screw 1 screw to assemble the photo sensor on color wheel module
2. Screw 2 screws to assemble color wheel module

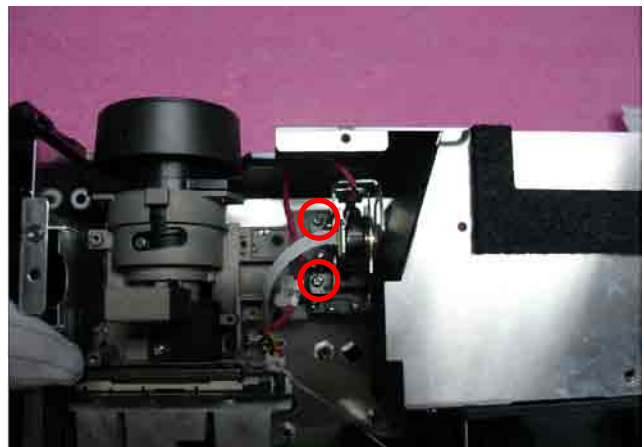

3. Screw 1 screw to assemble the mylar



*Mylar*



## 2-28 Assemble Main Board Module & Back Cover Module

1. Screw 2(4 for (X1260/X1260 Refresh/ X1260K Refresh) hex screws to assemble main board module & back cover module
2. Screw 1 screw on main board module & back cover module



Main Board Module



Back Cover Module



For X1160/X1160 Refresh/X1160Z/ X1160Z Refresh



For (X1260/X1260 Refresh/X1260K Refresh)



3. Screw 3 screws and 5 connectors to assemble main board module & back cover module (X1160/X1160 Refresh/ X1160Z/X1160Z Refresh)



Main Board Module&Back Cover Module

Screw 3 screws and 6 connectors to assemble main board module & back cover module(X1260/X1260 Refresh)



For (X1160/X1160 Refresh/X1160Z/X1160Z Refresh)

*Note: Speaker Cable(only for X1260)& Fan Cable must be fixed on Main Board by film tape to avoid to stretch into the Fan.*

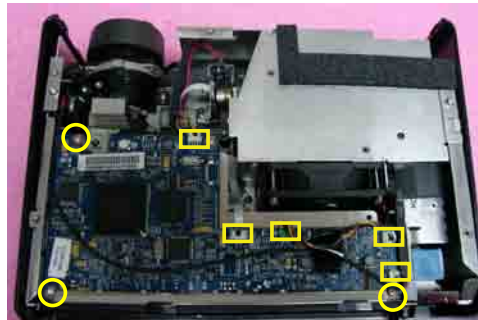

For (X1260/X1260 Refresh/X1260K Refresh)





## 2-29 Assemble Front Cover Module

1. Fasten four tenons to assemble the front cover module

- First, assemble the left side of the front cover: Fasten one tenon on bottom side, then fasten the tenon on top side of the bottom cover.
- Then, assemble the right side of the front cover as the left side

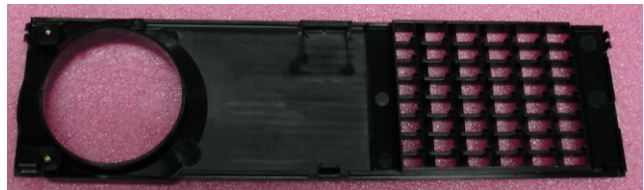

*Front Cover Module*



*Note: Avoid touch the lens when disassemble the front cover.*

2. Screw 1 screw on front cover module (for X1260/X1260 Refresh/X1260K Refresh)



## 2-30 Assemble Top Shielding

1. Screw 7 screws on the top shielding



*Top Shielding*



## 2-31 Assemble Top Cover Module

1. Assemble the top cover module on the model
2. Screw 2 screws on the unit base

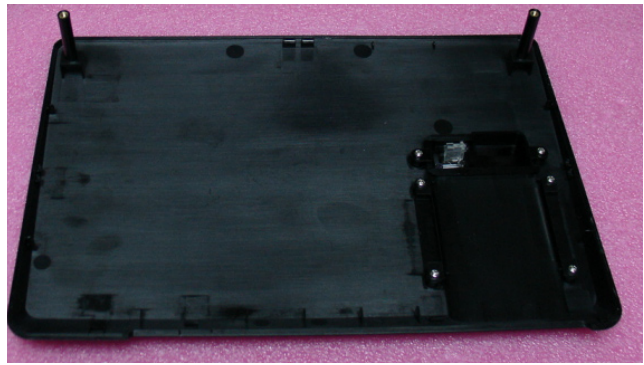

*Top Cover Module*



## 2-32 Assemble Lamp Module

1. Assemble the lamp module on the model
2. Screw 2 screws on the lamp module



Lamp Module

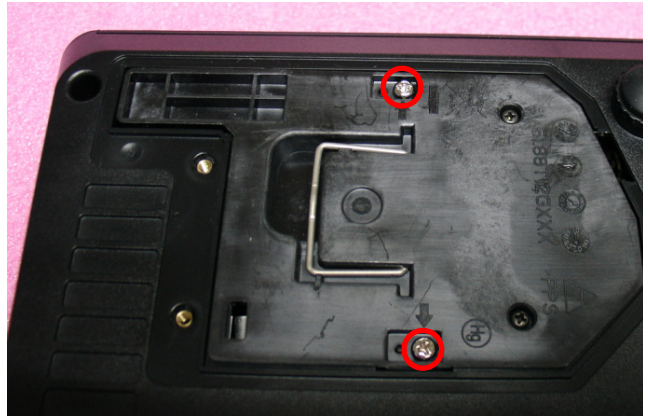

## 2-33 Assemble Lamp Cover Module

1. Assemble the lamp cover module
2. Screw 2 screws on the lamp cover module



Lamp Cover Module



# Troubleshooting

## 3-1 LED Lighting Message

Message	Power LED	
	Red	Blue
Input Power Plug	Flash ON to OFF 100ms	○
Standby	∨	○
Power button ON	○	∨
Lamp retry	○	Quick Flashing
Power off (Cooling state)	Quick Flashing	○
Power button OFF: Cooling completed; Standby Mode	∨	○
Error (Thermal Failure)	Quick Flashing RED and Steady BLUE by returns	
Error (Fan lock)	Quick Flashing RED and Steady BLUE by returns	
Error (Lamp breakdown)	Quick Flashing BLUE and Steady RED by returns	
Error (Color Wheel fail)	Quick Flashing BLUE and Steady RED by returns	

∨ *Light on*

○ *Light off*



## 3-2 Main Procedure

No	Symptom	Procedure
1	No Power	<ul style="list-style-type: none"> <li>- Ensure the Power Cord and AC Power Outlet are securely connected</li> <li>- Check Lamp Cover and Interrupt Switch</li> <li>- Ensure all connectors are securely connected and aren't broken</li> <li>- Check Lamp Driver</li> <li>- Check LVPS</li> <li>- Check Main Board</li> </ul>
2	Auto Shut Down	<ul style="list-style-type: none"> <li>- Check Power LED status               <ul style="list-style-type: none"> <li>a. Quick Flashing RED and Steady BLUE by returns                   <ul style="list-style-type: none"> <li>- Check Fan</li> </ul> </li> <li>b. Quick Flashing BLUE and Steady RED by returns                   <ul style="list-style-type: none"> <li>- Check Lamp</li> <li>- Check Lamp driver</li> </ul> </li> <li>c. Color Wheel                   <ul style="list-style-type: none"> <li>- Check Color Wheel</li> <li>- Check Photo Sensor</li> </ul> </li> </ul> </li> </ul>
3	No Image	<ul style="list-style-type: none"> <li>- Ensure the Signal Cable and Source work (If you connect multiple sources at the same time, use the "Source" button switch)</li> <li>- Ensure all connectors are securely connected and aren't broken</li> <li>- Check Main Board</li> <li>- Check DMD Board</li> <li>- Check Color Wheel</li> <li>- Check DMD Chip</li> <li>- Check Engine Module</li> </ul>

No	Symptom	Procedure
4	No Light On	<ul style="list-style-type: none"> <li>- Ensure all connectors are securely connected and aren't broken</li> <li>- Check Lamp Module</li> <li>- Check Lamp Driver</li> <li>- Check LVPS</li> <li>- Check Main Board</li> </ul>
5	Mechanical Noise	<ul style="list-style-type: none"> <li>- Check Color Wheel</li> <li>- Check Fan Module</li> </ul>
6	Line Bar/Line Defect	<ul style="list-style-type: none"> <li>- Check if the Main Board and the DMD Board are assembled properly</li> <li>- Check Main Board</li> <li>- Check DMD Board</li> <li>- Check DMD Chip</li> </ul>
7	Image Flicker	<ul style="list-style-type: none"> <li>- Do "Reset(All data)" of the OSD Menu</li> <li>- Ensure that the signal cables and source are work as well</li> <li>- Check Lamp Module</li> <li>- Check Color Wheel</li> <li>- Check DMD Board</li> <li>- Check Main Board</li> </ul>
8	Color Abnormal	<ul style="list-style-type: none"> <li>- Do "Reset(All data)" of the OSD Menu</li> <li>- Adjust Color Wheel Index</li> <li>- Check Main Board</li> <li>- Check DMD Board</li> <li>- Check Color Wheel</li> </ul>

No	Symptom	Procedure
9	Poor Uniformity/ Shadow	<ul style="list-style-type: none"> <li>- Ensure the projection screen without dirt</li> <li>- Ensure the projection lens is clean</li> <li>- Ensure the Brightness is within spec</li> <li>- Check rod alignment</li> <li>- Check Engine Module</li> </ul>
10	Dead Pixel/Dust (Out of spec.)	<ul style="list-style-type: none"> <li>- Ensure the projection screen without dirt</li> <li>- Ensure the projection lens is clean</li> <li>- Clean DMD Chip and Engine Module</li> <li>- Check DMD Chip- Check Engine Module</li> </ul>
11	Garbage Image	<ul style="list-style-type: none"> <li>- Ensure that the signal cables and source work as well</li> <li>- Check Main Board</li> <li>- Check DMD Board</li> </ul>
12	Remote Control/ Control Panel Failed	<ul style="list-style-type: none"> <li>- Remote Control <ul style="list-style-type: none"> <li>a.Check Battery</li> <li>b.Check Remote Controller</li> <li>c.IR receiver</li> <li>d.Check Main Board</li> <li>e.Check IR Board (for refresh models)</li> </ul> </li> <li>- Control Panel <ul style="list-style-type: none"> <li>a.Check Power Key</li> <li>b.Check Main Board</li> </ul> </li> </ul>
13	Function Abnormal	<ul style="list-style-type: none"> <li>- Do "Reset(All data)" of the OSD Menu</li> <li>- Check Main Board</li> <li>- Check DMD Board</li> </ul>



No	Symptom	Procedure
14	Forgetting Password (adminstrator Pass-word)	<p>- An unique Universal Password which is printed on the Security Card. This unique password is a back door of Administrator Password which will be accepted by projector anytime no matter what the Administrator Password is.</p> <p>- How to get the Universal Password?</p> <p>(1) Click the "AcerSNID"</p>  <p>(2) Input SNID number.(SNID number is on the Security Card)</p>  <p>(3) Click "Calculate". Then the Universal Password will appear.</p> 

### 3-3 Beep Sound

Power on (as soon as power button pressed)	So(0.3s)
Power on (lamp lighting failed)	2 x {So(0.1s) – Off(0.1s)} per lighting failure 12s interval for each trial lighting. Max 4 times of trial
Power on (lens cap was not opened, for the model with sliding lens cover only)	2 x {So(0.1s) – Off(0.1s)} periodically per 3 seconds, Totally 5 cycles. Turn off projector after 5 cycles.
Close lens cap while projector is operating (for the model with sliding lens cover only)	2 x {So(0.1s) – Off(0.1s)} periodically per 3 seconds, Totally 5 cycles. Turn off projector after 5 cycles.
Power off (power button pressed twice)	So(0.3s)
Fan lock	So(0.1s) periodically per second
Overheat	2 x {So(0.1s) – Off(0.1s)} periodically per second
Lamp error	3 x {So(0.1s) – Off(0.1s)} periodically per second
Lamp Life reminding	3 x {Do(0.2s) – Off(0.8s) – So(0.2s) – Off(0.8s)} with reminding message
Presentation Timer (time is up)	3 x {Do(0.1s) – Off(0.9s)} - So(0.5s)

# Function Test & Alignment Procedure

---

## 4-1 Test Equipment Needed

- IBM PC with SVGA/XGA resolution
- DVD player with Multi-system (NTSC/PAL/SECAM), equipped "Component", "S-Video", "Composite" and "HDMI".
- HDTV Source (480P, 720P, 1080i)
- Minolta CL-100
- Quantum Data 802B or CHROMA2327 (Color Video Signal & Pattern Generator)
- After changing parts, check the information below.

## 4-2 Service Mode

1. Turn on the projector and input the signal
2. Do the following actions sequentially to enter service mode menu
  - (1) Press "Power> Left>Left>Menu".
  - (2) Service mode will be shown.
  - (3) After confirming the configuration, press "Exit" to exit.

## 4-3 OSD Reset

1. After final QC step, we have to erase all saved change again and restore the OSD default setting. The following actions will allow you to erase all end-users' settings and restore the default setting:
  - (1) Please enter OSD menu.
  - (2) To execute "Reset" function.

## 4-4 Test Condition

- Circumstance brightness: Dark room less than 5.0 lux.
- Inspection distance: 1.8m~2.5m functional inspection.
- Screen size: 60 inches diagonal
- After repairing each X1160/X1260/X1160 Refresh/X1260 Refresh/X1160Z/X1160Z Refresh/X1260K Refresh, the unit should be run-in (refer to the table below)

Symptom	Run-in Time
Normal repair	2 hours
NFF	4 hours
Auto shutdown	6 hours

- Enter Burn-In Mode

\* Cycle setting is based on the defect symptoms. ie: If it is NFF, the run-in time is 4 hours. You have to set the lamp on for 50 min. and lamp off for 10 min for 4 cycles.

Press power > left > left > Menu	
Choose Burn-In Test > enter	
Lamp On (Min)	Press right key to adjust the time (50)
Lamp Off (Min)	Press right key to adjust the time (10)
Set burn in cycle	Press right key to adjust the cycle
After setting up the time, choose Burn-In mode and hit enter	

### Screen Defects (While replacing DMD Chip, DMD Board and Main Board)

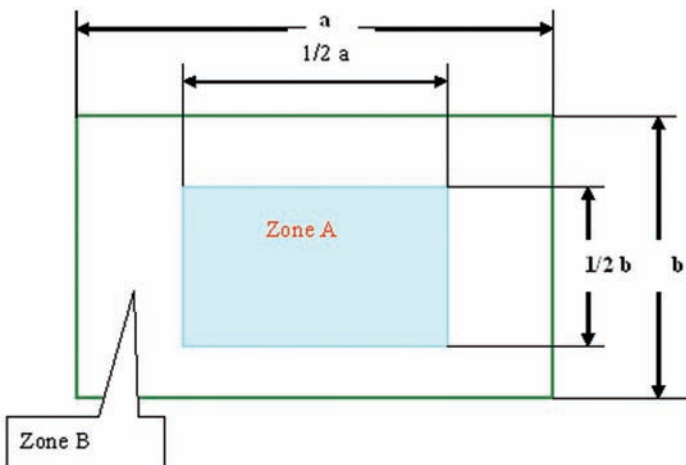

## 4-5 Test Inspection Procedure

Change parts/ Update	M/B	FW	Color Wheel	Lamp Module	Engine	EDID	Lamp Driver
Version Update	v	v				v	
Color Wheel Index	v		v				
PC Calibration	v	v					
Video Calibration	v	v					
Reset lamp hour				v			
OSD Reset	v	v					
EDID	v						
Re-write Lamp Hour Usage	v						
Reset Default Language (for refresh models)	v	v				v	
Rod Adjust					v		
Waveform Download (for refresh models)	v	v					v

## 4-6 PC MODE

*NOTE: Test Signal: analog 800 x600@60Hz(X1160 Refresh/X1160/X1160Z Refresh/X1160Z), analog 1024x768@60Hz(X1260 Refresh/X1260/X1260K Refresh). Take X1260 for example.*

### 1. Frequency and tracking boundry

- Procedure
- Test equipment: video generator.
  - Test signal: analog 1024 x 768@60Hz
  - Test Pattern: general-1 or master
  - Check if the image sharpness is well-performed.

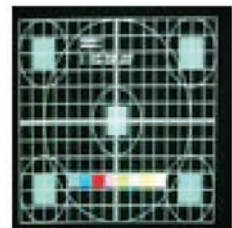

General-1



Master

- If not re-adjust by the following steps:
    - (1) Select "Frequency" function to adjust the total pixel number of pixel clock in one line period.
    - (2) Select "Tracking" function and use right or left arrow key to adjust the value to minimize video flicker.
  - Adjust Resync or Frequency/Tracking/H. Position/V. Position to the inner screen.
- Inspection item
- Eliminate visul wavy noise by Rsync, Frequency or Tracking selction.
  - Check if there is noise on the screen.
  - Horizontal and vertical position of the vedio should be adjustable to the screen frame.
- Criteria
- If there is noise on the screen, the product is considered as faliture product.
  - If there is noise on the screen, use auto or manul "frequency" function or "tracking" function to adjust the screen.
  - The PC mode functionally sure be workable include support format with frequency and auto detected functional will be workable.

## 2. Light Leak

- Procedure
- Test equipment: video generator.
  - Test signal: analog 1024x768@60Hz
  - Test Pattern: gray 10 patterns
  - Check if the light leaks.
  - \* Light leak on reflective edge, eyecatcher, bond-wires and exposed metal.



Gray 10

- Inspection item
- Light leak check.
  - Bright blemish (dirty).
- Criteria
- The bright blemish is unacceptable when it is more than four under gray 10 pattern
  - Ref. below table
- Note: The defect criteria follows TI specification.



Blue 60

## 3. Blemish (Dark)

Procedure - Test equipment: video generator.  
 - Test signal: analog 1024x768@60Hz.  
 - Test Pattern: blue 60

Inspection item - Dark blemish check.(dirty)

Criteria -The dark blemish is unacceptable when it is more than four under blue 60 pattern  
 - Ref. below table  
 Note: The defect criteria follows TI specification.

#### 4. Dead Pixel (Bright pixel)

Procedure - Test equipment: video generator.  
 - Test signal: analog 1024x768@60Hz.  
 - Test Pattern: full black

Inspection item - Bright pixel check.  
 Note: Frame dimension under operative zone1 inch

Criteria - Bright pixel is unacceptable.  
 - Ref. below table  
 Note: The defect criteria follows TI specification.



Full black

#### 5. Dead Pixel (Dark pixel)

Procedure - Test equipment: video generator.  
 - Test signal: analog 1024x768@60Hz.  
 - Test Pattern: full white

Inspection item - Dead pixels check.  
 - White pattern (IRE=100)  
 - Adjacent dark pixel.

Criteria - The number of the dead pixels should be less or equal to 6 pixels.  
 - Adjacent pixel with each other is unacceptable.



Full white

- Ref. below table
- Note: The defect criteria follows TI specification.



Full screen

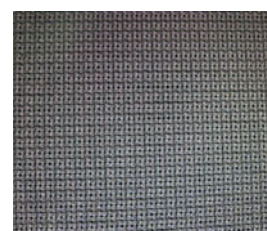

MEME Sony

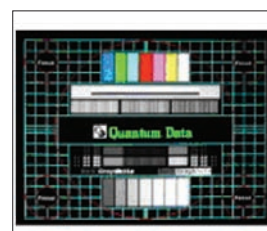

Master



InFocus II  
/ 64 gray RGBW

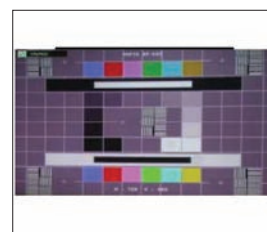

SMPTE RP-133

## 6. Focus test

- Procedure
- Test equipment: video generator.
  - Test signal: analog 1024 x 768@60Hz
  - Test Pattern: full screen or MEME Sony
- Inspection item
- Focus check
- Criteria
- From screen 1.5 M via visual to check the focus, look at the entire screen, focus shall be clear, crisp, and sharp over the entire surface of the display pattern. (Blur word on one of the corner after adjustment is acceptable. However, the word should at least be recognizable.)

## 7. Color performance

- Procedure
- Test equipment: video generator.
  - Test signal: DVI (HDMI) 720p, 1080i
  - Test Pattern: Master, In focus II or SMPTE RP-133
  - \* Please refer to 4-2 to enter service mode. Use 720P & 1080i signal, master pattern to do HDTV test. Color cannot discolor to purple and blue. If the test result is discoloration or flickering, please return the unit back to repair centers.
- Inspection item
- Check if each color level is well-functioned.
  - color saturations
- Criteria
- Screen appears normal. It should not have any abnormal condition, such as lines appear on the screen and so on.
  - Color appears normal.
  - It is acceptable to have few lines flashing at the center and on the edge of 1080i image. However, rest of the image should appear stable.
  - RGBW should all appear normal on the screen and sort from R -G-B-W.
  - Color levels should be sufficient and normal.



(the unidentified color levels on both left and right sides should not over 8 color levels.)

- Grey level should not have abnormal color or heavy lines.
- The PC mode functionally sure be workable include support format with frequency and auto detected functional will be workable

## 4-7 Calibration

### 1. YPbPr calibration

#### Procedure

- Test equipment: video generator.
- Once main board is changed, YPbPr calibration should be done as well.
  - (1) Test signal: 480P
  - (2) Test Pattern: SMPTE BAR
- Note
  - (1) Calibration pattern should be in fill screen mode.
  - (2) Please refer to 4-2 Guide to Entering Service Mode and OSD Reset.
  - (3) Choose and access YPbPr Calibration for correction in service mode. Choose "menu" to leave the service mode after all.

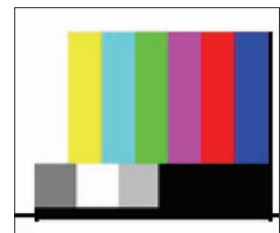

SMPTE BAR

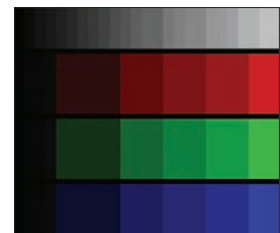

In focus II / 64 Gray  
RGBW

#### Check pattern

- Test signal: 480P
- Test pattern: In focus II or 64 gray RGBW
  - \* After finishing ADC adjustment, check 64 gray RGBW pattern.

#### Inspection item

- Color saturations

- Criteria
- There should not have any lack of RGBW. The color should appear normal and sort in right order.
  - Color levels should be sufficient and normal. (the unidentified color levels on both left and right sides should not over 8 color levels.)
  - Grey level should not have abnormal color or heavy lines.

## 2. PC calibration

- Procedure
- Test equipment: video generator
  - Once main board is changed, PC calibration should be done as well.
    - (1) Test signal analog: 1024x768@60Hz
    - (2) Test Pattern: White(up) Black(down)
  - Note
    - (1) Caibration pattern should be in fill screen
    - (2) Please refer to *4-2 Guide to Entering Service Mode and OSD Reset.*
    - (3) Choose and access PC Calibration for correction in service mode. Choose "menu" to leave the service mode after all.



White / Black

mode.

- Check pattern
- Test signal: analog 1024 x 768@60Hz
  - Test pattern: In focus II or 64 gray RGBW
  - \* After finishing ADC adjustment, check 64 gray RGBW pattern.



In focus 2 / 64 gray RGBW

- Inspection item
- Color sturations
- Criteria
- There should not have any lack of RGBW. The color should appear normal and sort in right order.
  - Color levels should be sufficient and normal. (the unidentified color levels on both left and

- right sides should not over 8 color levels.)
- Grey level should not have abnormal color or heavy lines.

## Defect specification table

Order	Symptom	Pattern	Criteria
1	Bright pixel ( dots)	Black pattern ( IRE=0)	A+B=0
2	Dark pixel(dots)	White pattern	A+B=6
3	Unstable pixel (dots)	Any pattern	A+B=1
4	Adjacent dark pixel (dots)	Any pattern	A+B=0
5	Dark blemish (Dirty)	Blue 60 pattern	A+B=4 (diameter <1/2 inch)
6	Bright blemish (Dirty)	Gary 10 pattern	A+B=4 (diameter <1/2 inch)
7	Bright dot on frame	Black pattern	2

## 4-8 Video Performance

### 1. CVBS

- Procedure
- Test equipment: DVD player
  - Test signal: CVBS
- Inspection item
- Video performance test
- Inspection Distance
- 1.8M ~2.5M
- Criteria
- Check any abnormal color, line distortion or any noise on the screen.



*Motion video*

- Check the sound from speakers.(Only for X1260 Refresh/X1260/X1260K Refresh)

## 2. S-Video

- Procedure
- Test equipment: DVD player
  - Test signal: S-Video
- Inspection item
- Video performance test
- Inspection Distance
- 1.8M ~2.5M
- Criteria
- Check any abnormal color, line distortion or any noise on the screen.
  - Check the sound from speakers. (Only for X1260 Refresh/X1260/X1260K Refresh)

## 3. HDTV/ Component

- Procedure
- Test equipment: DVD player
  - Test signal: Ycbcr/YPbPr
- Inspection item
- HDTV performance test
- Inspection Distance
- 1.8M ~2.5M
- Criteria
- Check any abnormal color, line distortion or any noise on the screen.
  - Check the sound from speakers. (Only for X1260 Refresh/X1260/X1260K Refresh)

## 4. Audio Test (Only for X1260 Refresh/X1260/X1260K Refresh)

- Procedure
- Test equipment: DVD player
  - Test signal: CVBS
- Inspection item
- Audio performance test
- Inspection Distance
- 1.8M ~2.5M
- Criteria
- Check the sound from speakers.
  - Check "Volume" is normal
  - Check "Mute" is normal

## 4-9 Optical Performance Measure

Inspection Condition
- Environment luminance: 5 Lux
- Product must be warmed up for 3 minutes
- Distances from the screen: <Max. zoom & 60 inches diagonal> 1.8 M
- Screen Size: 60 inches diagonal
- Reset to default before measurement

### 1. Test equipment

- Procedure
- Test equipment: video generator.
  - Test signal: analog 1024x768@60Hz.

### 2. Brightness

- Procedure
- Full white pattern
  - Use CL100 to measure brightness values of P1~P13.
  - Follow the brightness formula to calculate brightness values.
- ☀ Brightness Formula
- $$\text{Avg.}(P1 \sim P9) \times 1.1 \text{m}^2$$
- Criteria
- 800 lumens (for X1160/X1260/X1160Z)
  - 900 lumens (for X1160 refresh/X1260 refresh/X1160Z refresh/X1260K refresh)

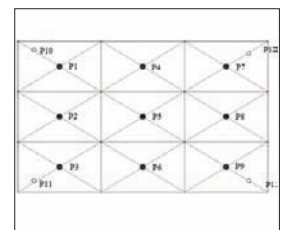

Full white pattern

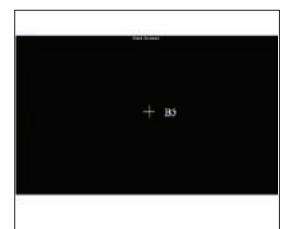

Full black pattern

### 3. Full On/Full Off Contrast

- Procedure
- Full white pattern & full black pattern
  - Use CL100 to measure brightness values of full white pattern P5 & full black pattern B5 ( see image: full white)
  - Follow Contrast formula to calculate contrast values.
- ☀ Contrast Formula
- P5/B5
- note: P5=center of white image  
B5 = the center of black image.
- Criteria
- 1500:1 (X1160/X1260/X1160Z)
  - 1400:1 (X1160 Refresh/X1260 Refresh/X1160Z Refresh)
  - 400:1 (only for X1260K Refresh)

### 4. Uniformity

- Procedure
- Full white pattern
  - Use CL100 to measure brightness values of P1~P13 (see image: full white).
  - Follow the Uniformity formula to calculate average values.
- ANSI Uniformity = Avg. (P1, P3, P7, P9)/P5X100%
- Criteria
- 65 %

## 4-10 Others

### 1. Functional Inspection

- Keypad button - All keypad buttons must operate smoothly.
- General - All OSD functions must be checked for functionality. When OSD menu is displayed, there shall be no visible peaking, ringing, streaking, or smearing artifacts on the screen.
- Factory Default - The factory settings (with appropriate centering, size, geometry distortion, etc.) shall be displayed upon "Recall" is selected from OSD
- Display Size - All preset modes shall expand to fullscreen size using OSD Horizontal and Vertical Size controls-
- Display Data Channel (DDC) - The purpose of the DDC test is to verify the DDC1/DDC2B operation of the projector and to verify Plug & Play function.
- Acoustic - High pitch sound from cooling fan and color wheel unacceptable.

**r exterior and print pattern**

Check item	Check point
Text & Pattern	missing letters & pattern or blurry prints are unacceptable.
Exterior	dirt, scrape, water ripples and uneven color are unacceptable.
Buttons	stuck buttons are unacceptable.
Focus ring	Focus ring is functioning smoothly.
Logo	missing logo, missing prints and blurry prints are unacceptable
Screw	All screw sure be fixed and in right type.

# Firmware Upgrade

---

## 5-1 Equipment Needed

### Software : (DDP 2230- USB)

- DLP Composer
- Firmware
- Library file (library file has to put in PC and set right path in step of 5-4-4 Firmware Upgrade Procedure)

### Hardware :

- Projector
- Power cord (42.53506G002)
- USB Cable (42.87304G001)
- PC or Laptop





## 5-2 DLP Composer Lite Setup Procedure

1. Choose “DLP Composer Lite V7.1 Setup” Program.
2. Click “Next” button.
3. Read “License Agreement”.
  - Choose “I accept and agree to be bound by all the terms and conditions of this License Agreement”.
4. Click “Next”.
5. Click “Next”.

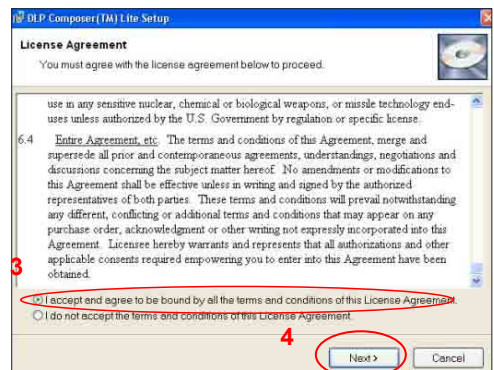

6. Click "Next".

7. Click "Next".

8. Writing system registry values.

9. Click "Finish".

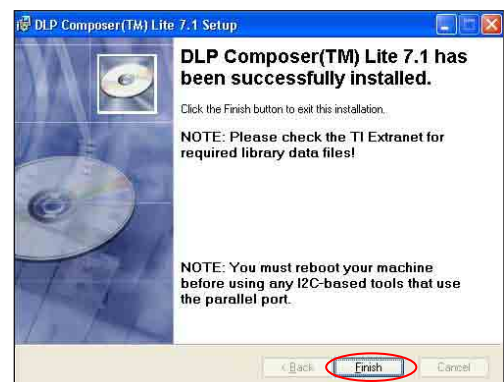
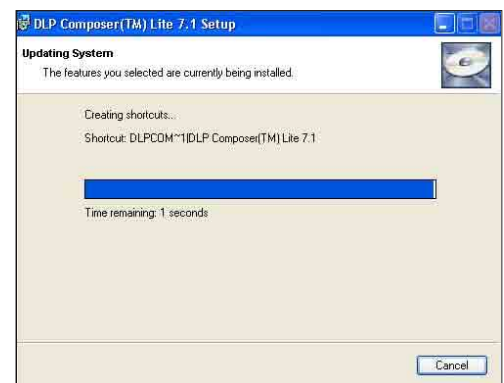
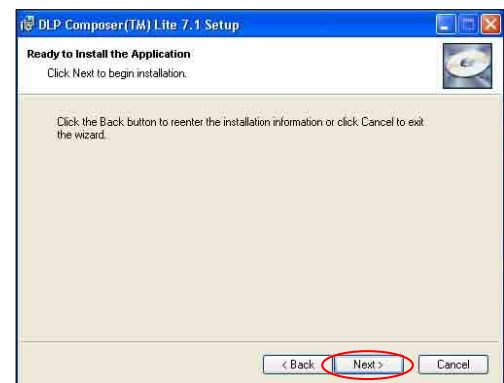
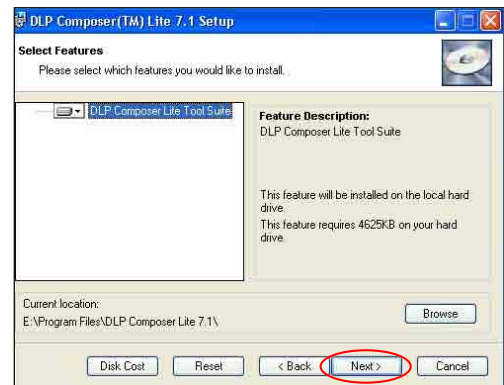

## 5-3 USB Driver Upgrade Procedure

### 1. set up

- Plug in Power cord to projector.
- Link PC USB port and projector USB port by USB Cable.

### 2. Execute Program

- (1) "Found new hardware wizard" will be appeared on the screen.
- (2) Select "Install the software automatically (Recommended)".
- (3) Then click "Next".

### 3. Finish

- Click "Finish" to end the installation.

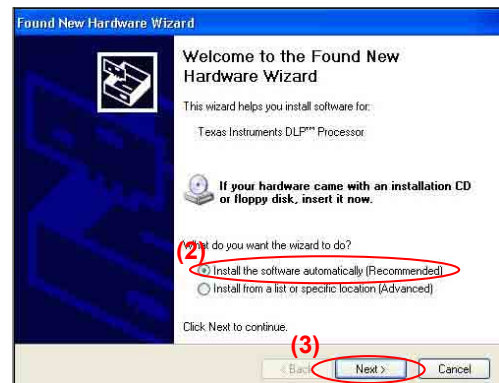

## 5-4 Firm Upgrade Procedure

- Take X1160 for example, X1260/X1160 Refresh/  
X1260 Refresh/X1160Z/X1160Z Refresh/  
X1260K Refresh is the same as X1160

### 1. Set-up

- Hold on “Power” and plug in power cord while holding on “Power”.
- Once the power LED lights on Blue&Red at the same time, plug in USB cable into the projector and link to the USB port of a PC.

*Note: The system fan and the light will not operated.*

### 2. Execute the “DLP Compose™” file.

### 3. Click “edit” and “perferences”.

### 4. Click “Library”.

- The library path located in the default installation directory.
- E:\ Program Files\DLP Composer Lite 7.1\ library v7.1 0330.

*Note: If not, press “Browse” to select the right path.*

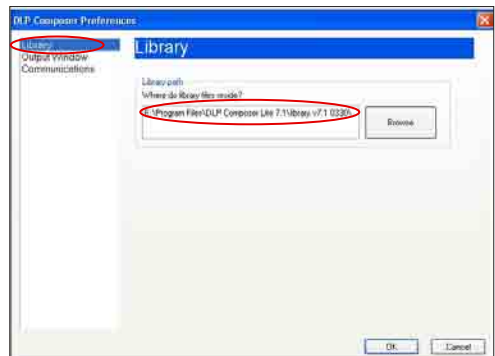
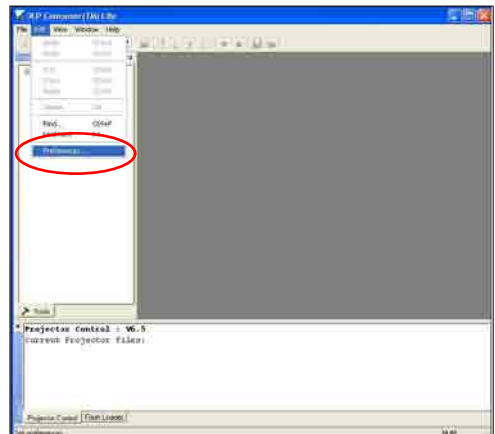

5. Select “Edit\preferences\Communications”  
- choose “USB.” Click “OK”.

6. Choose “Flash Loader”.  
- Click “Browse” to search the firmware file.  
(X1160/X1160 Refresh).

7. Select the item “skip Boot Loader Area”  
(select 16KB).  
- Click “Reset Bus” to erase the flash  
memory.

8. If the firmware is ready, click “start  
download” to process the firmware  
upgrade.  
- Click “Yes” to erase the flash memory.

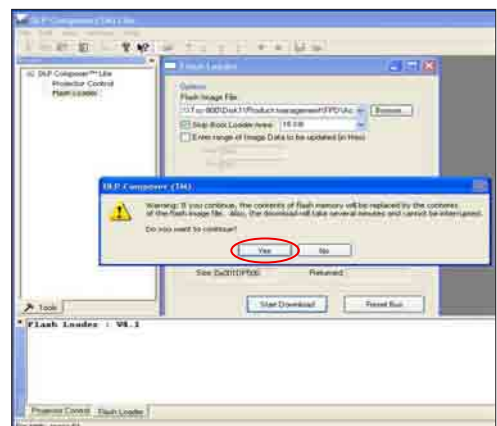
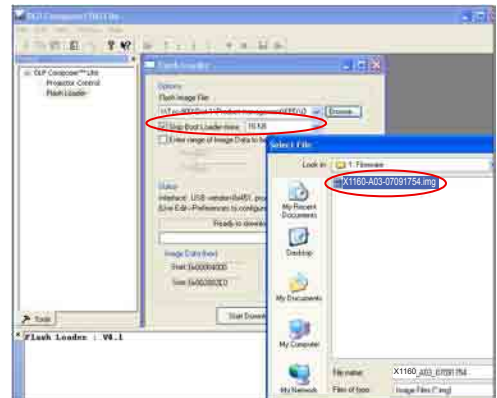
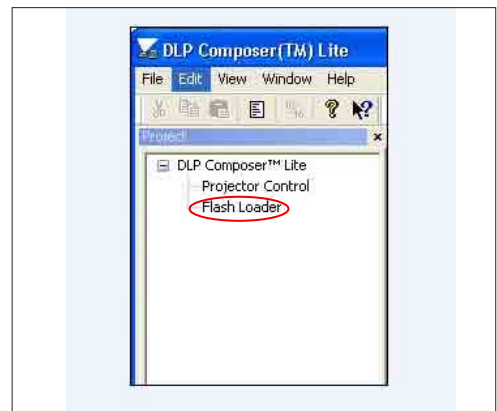
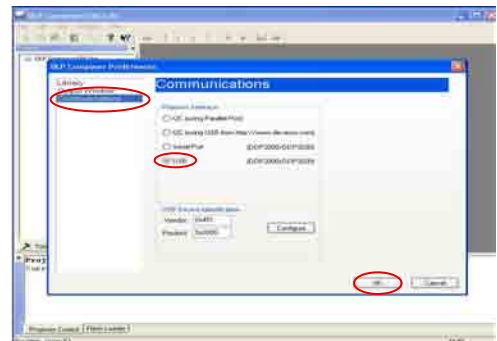

9. When firmware upgrade process is finished, the unit return to stand-by status  
 The LED power lights on and appears Red.  
 -Unplug USB cable and power cord and replug in power cable.

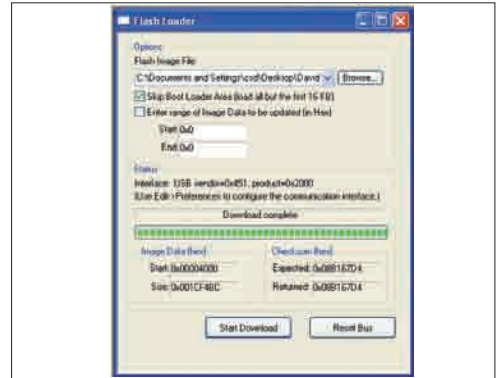

10. Restart the unit and enter the service mode to check the firmware version.  
 (To enter service mode, please refer to Chapter 4 Function Test and Alignment Procedure.)

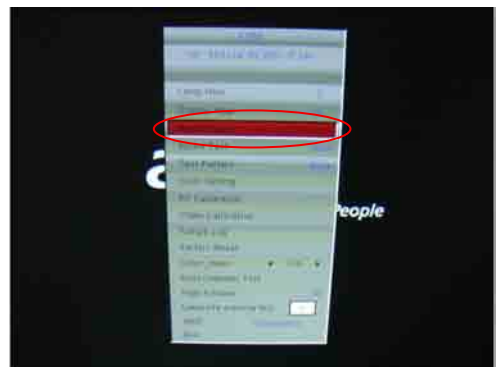

## 5-5 Waveform Download (for refresh models)

(1) Hold on “Power“ button then plug in the Power Cord

*Note: At this moment ,Power LED flash in blue and red about 2 seconds until Power LED flash in blue only for 2 seconds, please release the power botton*

(2) After flashing, LED is in steady condition and you can judge the actions as the following table:

Power LED status	Result
Red	OK
Blue + Red (It will light on red only after 10 seconds)	Fail

# EDID Upgrade

---

## 6-1 EDID Introduction

Extended Display Identification Data is a VESA standard data format that contains basic information about a display device and its capabilities, including vendor information, maximum image size, color characteristics, factory pre-set timings, frequency range limits, and character strings for the monitor name and serial number.

The information is stored in the display and is used to communicate with the system through a Display Data Channel (DDC), which sits between the display device and the PC graphics adapter. The system uses this information for configuration purposes, so the monitor and system can work together.

*Note: If a display device has digital input ports, like DVI or HDMI, but without EDID in its main board, the display device will show no image while the input source is digital signal. After EDID upgraded, do " default language reset"*



## 6-2 Equipment Needed

### Software

- EDID Program (Generic V0.51)
- EDID File \*.ini

### Hardware

- Projector
- Generic Fixture (80.58704.001) for EDID Key-in (Fixture: JP3 must be closed)
- Power cord(42.53506G002)
- RS-232 Cable (pin to pin, F-M)
- Monitor
- PC
- VGA cable(42.00201G001)
- Power adapter for fixture (47.57702G001)

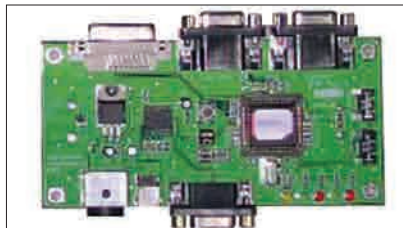

## 6-3 Setup Procedure

1. Connect all ports
  - Power adapter to fixture JP1
  - Fixture P1 to PC COM1 Port
  - Fixture P2 to Projector analog port

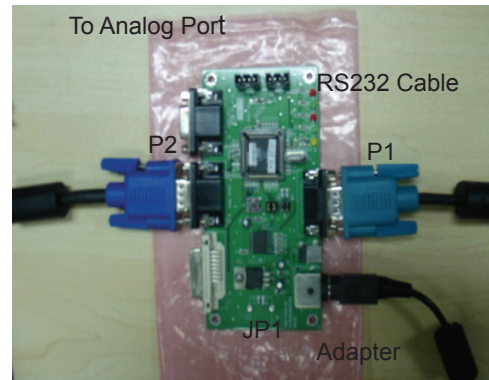

## 6-4 EDID Key-In Procedure

- Take X1160 for example, X1260 /X1160 Refresh / X1260 Refresh/X1160Z/X1160Z Refresh/X1260K Refresh is the same as X1160

1. Click on "EDID" to execute EDID program



2. Choose model

- (1) In the port selection bar, please choose the port that you use. ie: if you use "COM1", choose COM1 in the port selection.

- (2) Click on "Model".

- (3) Choose the EDID that responds to the model that you choose.

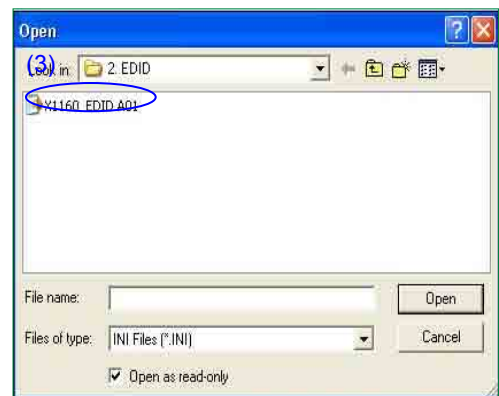
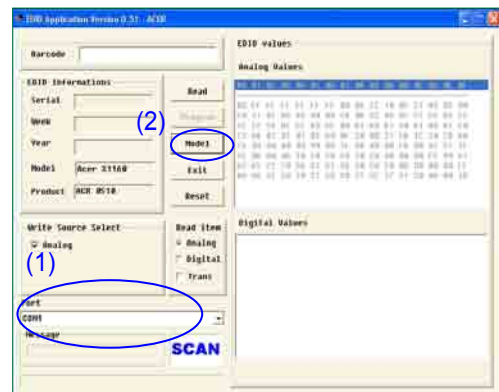

### 3. Programming

- (1) Key in the serial number into the barcode blank space.
- (2) In "Write Source Select" make a check in "Analog".
- (3) Click "Program".

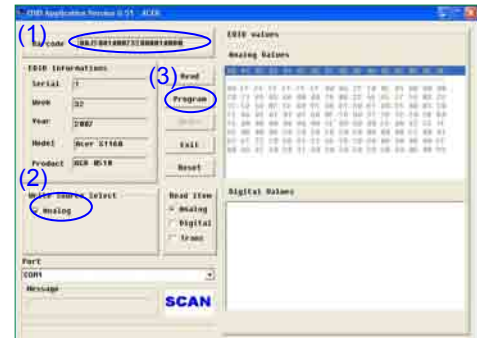

### 4. Change the cable to Analog

- Message box appears on the screen, then click "OK".



5. When the EDID program for VGA is completed, a message "OK" will appear on the screen.

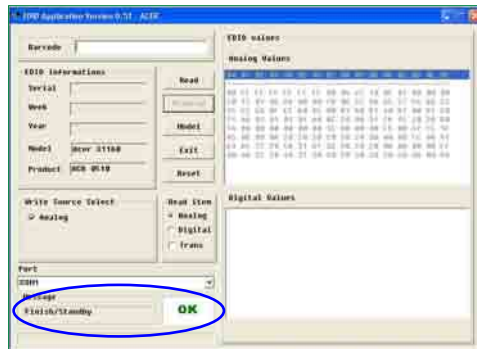

6. (1) In the Read item, select "Analog" and "Trans".

- (2) Please press "Read" button.

7. EDID Informations will show the result.

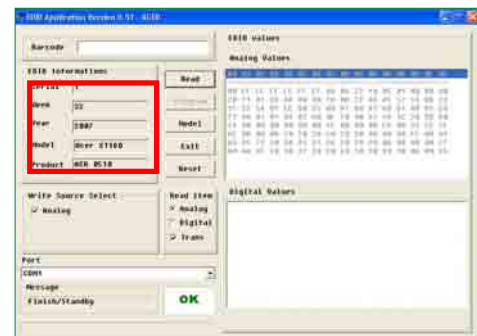
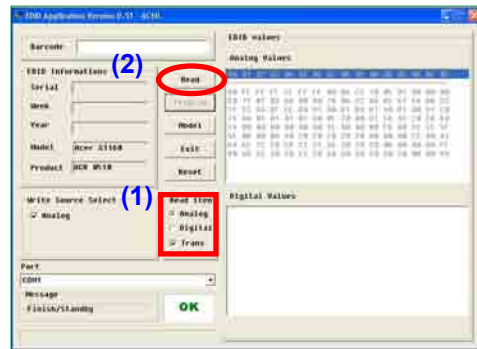

## 6-5 Default Language Reset (for refresh models)

(1) Hold on “Power“ button then plug in the Power Cord

*Note: At this moment ,Power LED flash in blue and red about 2 seconds until Power LED flash in blue only for 2 seconds, please release the power botton*

(2) After flashing, LED is in steady condition and you can judge the actions as the

following table:

Power LED status	Result
Red	OK
Blue + Red (It will light on red only after 10 seconds)	Fail

*Note: if fail, please do the actions as above steps item (1)-(2)*

S/N General rule :



*Use the last 1 digit code (as red word) for language information*

Language Code (F)	Default Language
1	English
2	Thailand
3	Japan
4	TC
5	SC
6	Russian
7	Germany
8	Hungarian

---

# Appendix A

---

## Assy Lamp Module X1160

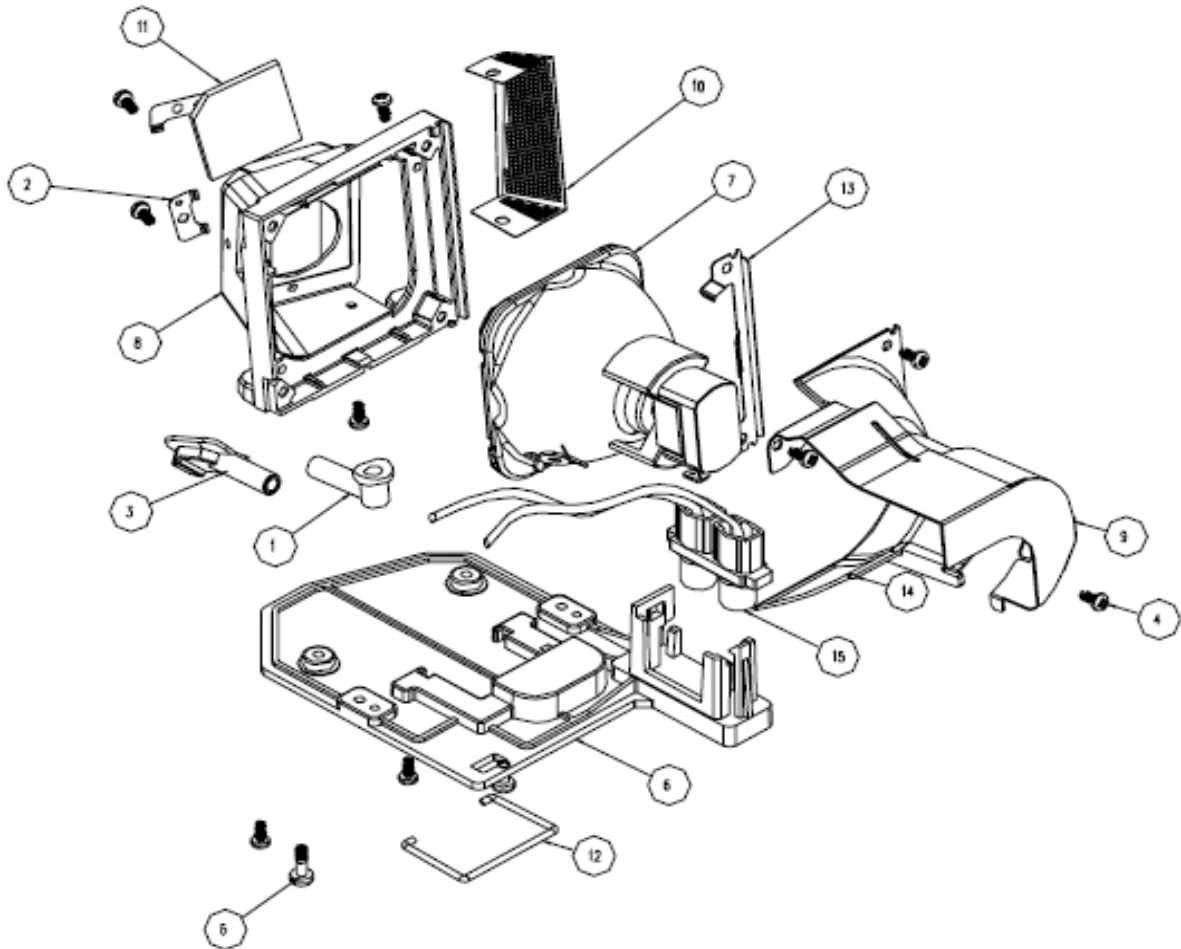

item	P/N	Rev	Description	Parts Supply
1	52.83F12G001	A	LAMP RUBBER HD72	
2	61.80L06G001	A	UVIR SPRING PLATE SUS301 80L	
3	52.85902G012	A	LAMP CONTACT COVER RUBBER 300C	
4	85.1A326G050	A	SCREW PAN HEAD MECH M2.6*5 BLACK	
5	61.00061G001	A	LOCK SCREW PAN MECH M3*8.5-3.5 Ni	
6	51.88T12G001	A	LAMP BOTTOM X1160	
7	23.88T15G001	A	OSRAM P-VIP 150-180/1.0 E20.6	
8	61.88T01G001	A	LAMP HOLDE OSRAM E206 X1160	
9	61.88T10G001	A	LAMP LIGHT CUT AL X1160	
10	61.88T11G001	A	LAMP LEFT MESH X1160	
11	23.87M10G001	A	UV-IR 24*25*2mm(5*5mm cut)UNAXIS	
12	61.86808G001	A	LAMP CHANGER HANDLE SUS DP725	
13	61.83F12G001	A	LAMP CLAMP SUS301 t=0.3 HD72	
14	61.83M17G001	B	LAMP LIGHT CUT 2400MP	
15	76.83M02G002	A	OUTSIDE W.A. 85/95mm FOR 2400MP	

## ASSY MAIN-BD MODULE X1160

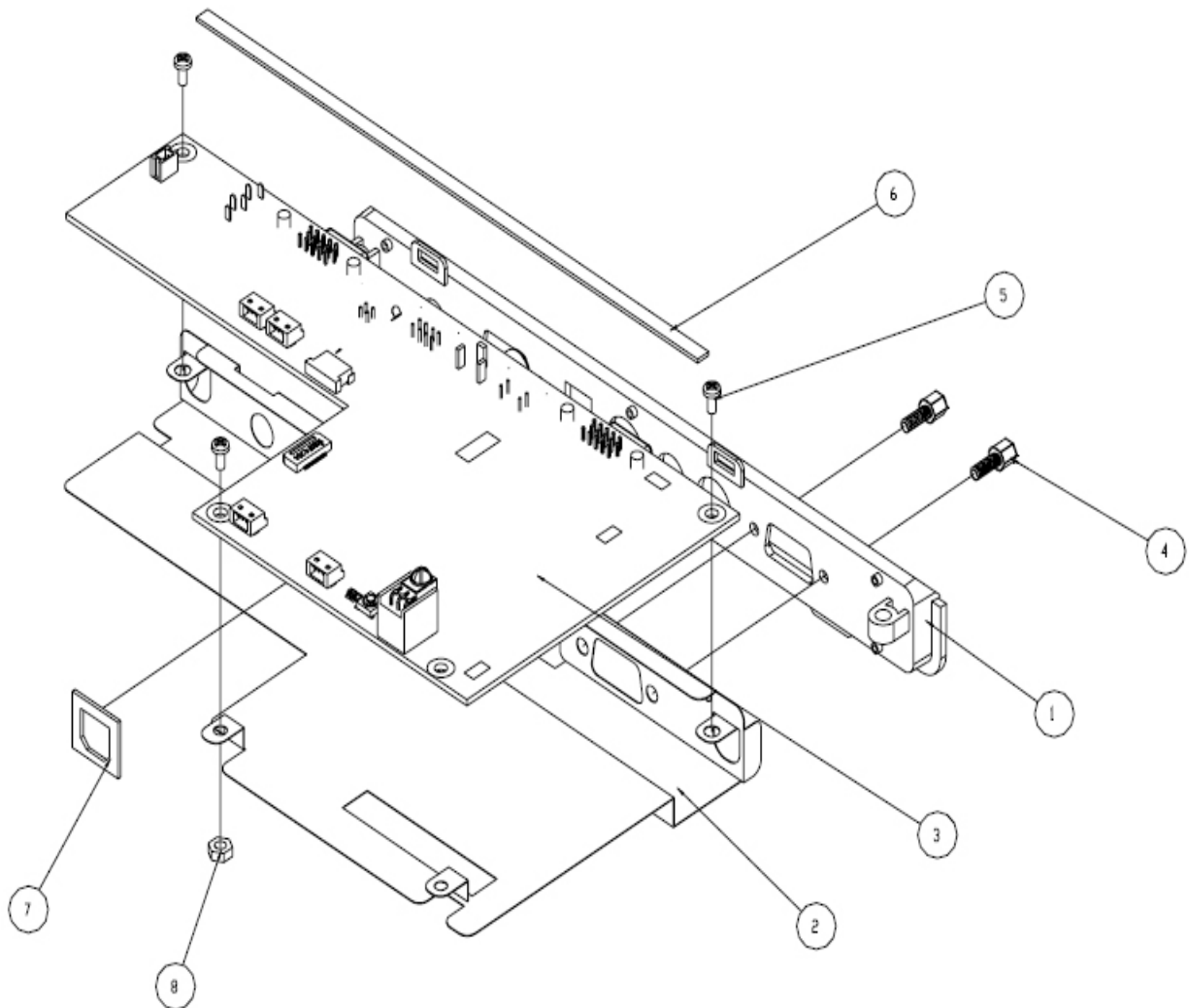

item	P/N	Rev	Description	Parts Supply
1	51.88T04G001	A	IO COVER X1160	
2	61.88T16G001	A	SHIELDING MAIN-BD X1160	
3	80.88T01G001	A03	PCBA MAIN BOARD FOR X1160	
4	85.005AGG075	A	SCREW HEX I/O #4-40*H5*L7.5 Ni NYLOK	
5	85.1A123G060	A	SCREW PAN MECH M3*6 NI	
6	41.88T02G001	A	EMI GASKET L180*W4*H1	
7	41.82G03G001	A	EMI GASKET USB CONNECTOR EP719	
8	86.0A123G024	A	HEX NUT M3*0.5P L2.4 Ni	

# ASSY ENGINE MODULE X1160

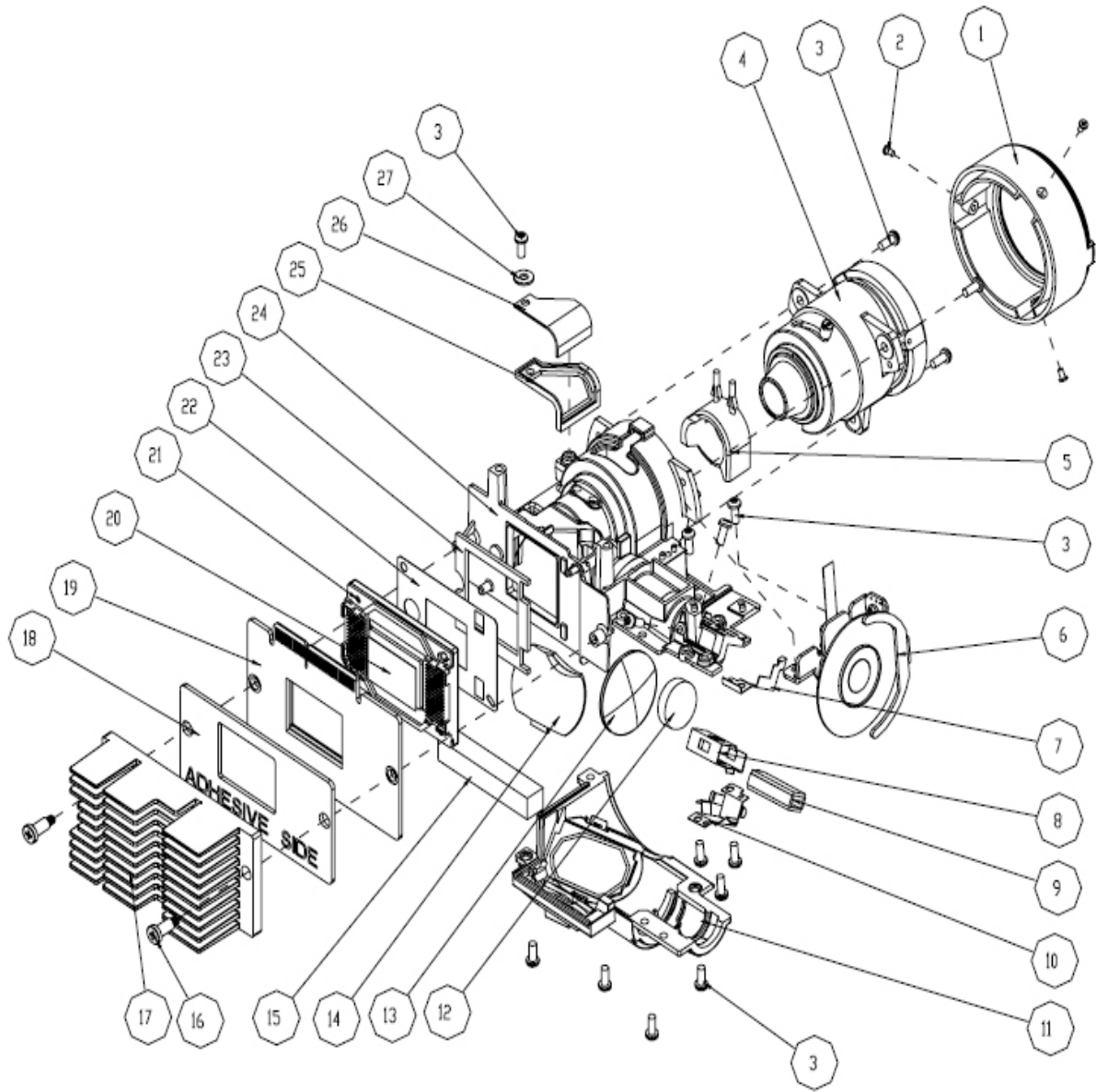



item	P/N	Rev	Description	Parts Supply
1	51.88T09G001	A	FOCUS RING X1160	
2	85.WA321G050	A	SCREW PAN HEAD M1.7*5 BLACK "	
3	85.1A126G060	A	SCREW PAN MECH M2.6*6 Ni	
4	23.88T01G001	A	YO PROJECTION LENS YM09XS FOR X14	
5	52.89F01G001	A	PROJECTION LENS RUBBER HD65	
	70.88T11GR11		ASSY NEW COLOR WHEEL MODULE X1	V
6	70.88T08G001	A	ASSY COLOR WHEEL MODULE X1160	V
7	61.88N13G001	A	ROD COVER SUS301,X15	
8	61.88N14G001	A	ROD HOLDER SUS301,X15	
9	23.88N17G001	A	YO INTEGRATING ROD FOR x15	
10	61.88N12G001	A	ROD SPRING SUS301,X15	
11	70.88T07G001	A	ASSY ENGINE BOTTOM MODULE X1160	
12	23.88N20G001	A	YO CONDENSER1 FOR X15	
13	23.88N20G011	A	YO CONDENSER2 FOR X15	
14	23.88N06G002	A	PRODISC X15 PLASTIC RELAY LENS	
15	41.85W05G001	A	EMI GASKET W8*H8*L45	
16	85.4A826G118	A	STEP SCREW FOR TYPEX DMD M2.6*11.8mm,X15	V
17	61.88N03G001	A	DMD HEAT SINK AL1070,X15	
18	52.88N03G001	A	HEAT SINK RUBBER,X15	
19	80.88T02G001	A03	PCBA DMD BOARD FOR XD1130	
20	52.87J01G001	A	DMD THERMAL PAD 25*17*0.5t FUJIPOLY SARGON GR-Hn	V
21	48.87K01G001	A	DMD Type-X 800x600 PIXEL 0.55" SVGA LVDS "TI"	V
22	61.88N15G001	A	DMD MASK SUS301,X15	
23	52.88N04G001	A	DMD RUBBER,X15	
24	61.88N01G001	A	ENGINE BASE MG,X15	
25	52.88N01G001	A	OFF RAY RUBBER,X15	
26	61.88N05G001	A	OFF RAY PLATE AL5052,X15	
27	87.FL030G008	A	WASHER FLAT 7*3.1*0.8t PC PINGOOD WS-1M	

## ASSY ENGINE BOTTOM MODULE X1160

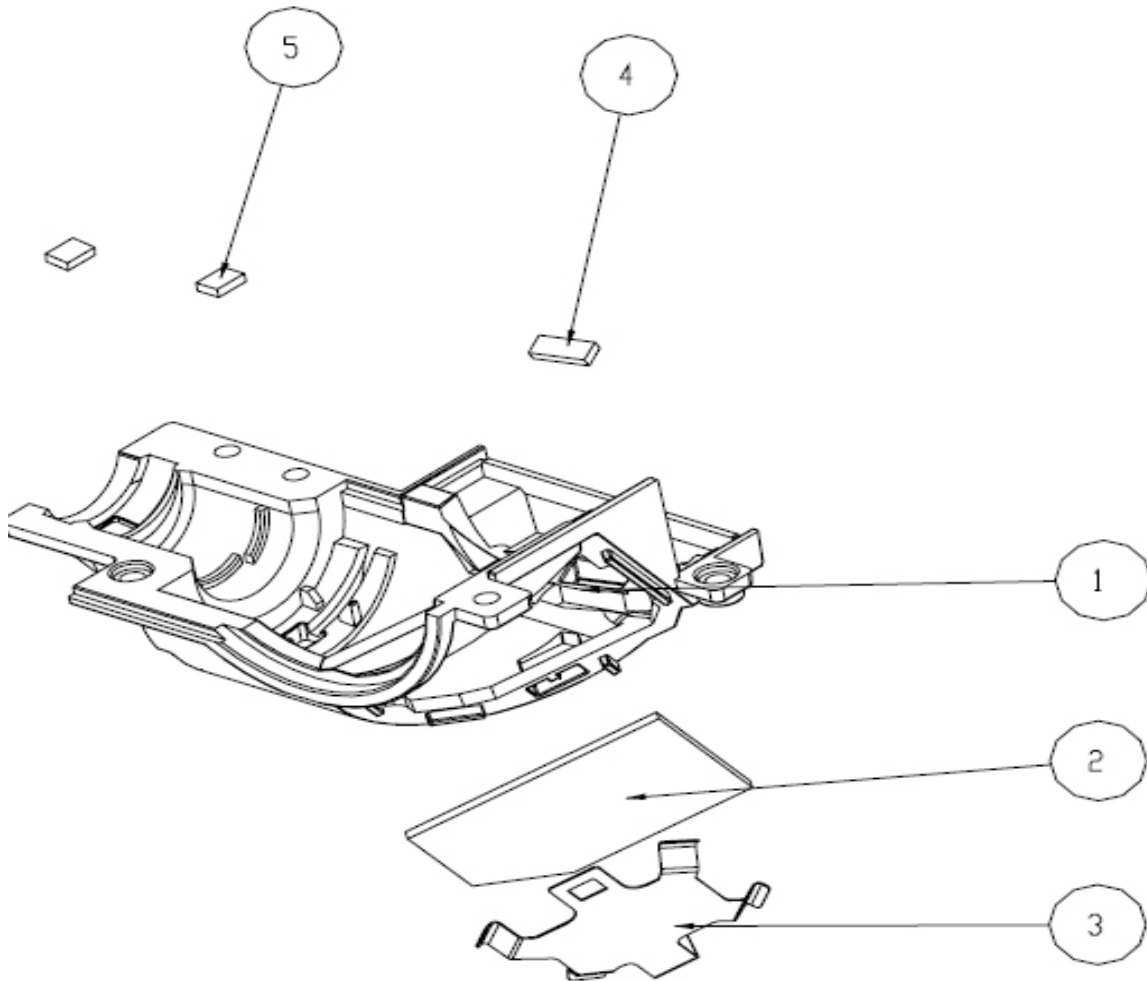

item	P/N	Rev	Description	Parts Supply
1	51.88N01G001	A	ENGINE BOTTOM COVER PC945,X15	
2	23.88N02G001	A	YO MIRROR1 FOR X15	
3	61.88N11G001	A	MIRROR SPRING SUS301,X15	
4	52.88N05G001	A	RELAY RUBBER,X15	
5	52.85808G001	A	PORON-LENS BLACK XB31	

# ASSY HOUSING MODULE X1160

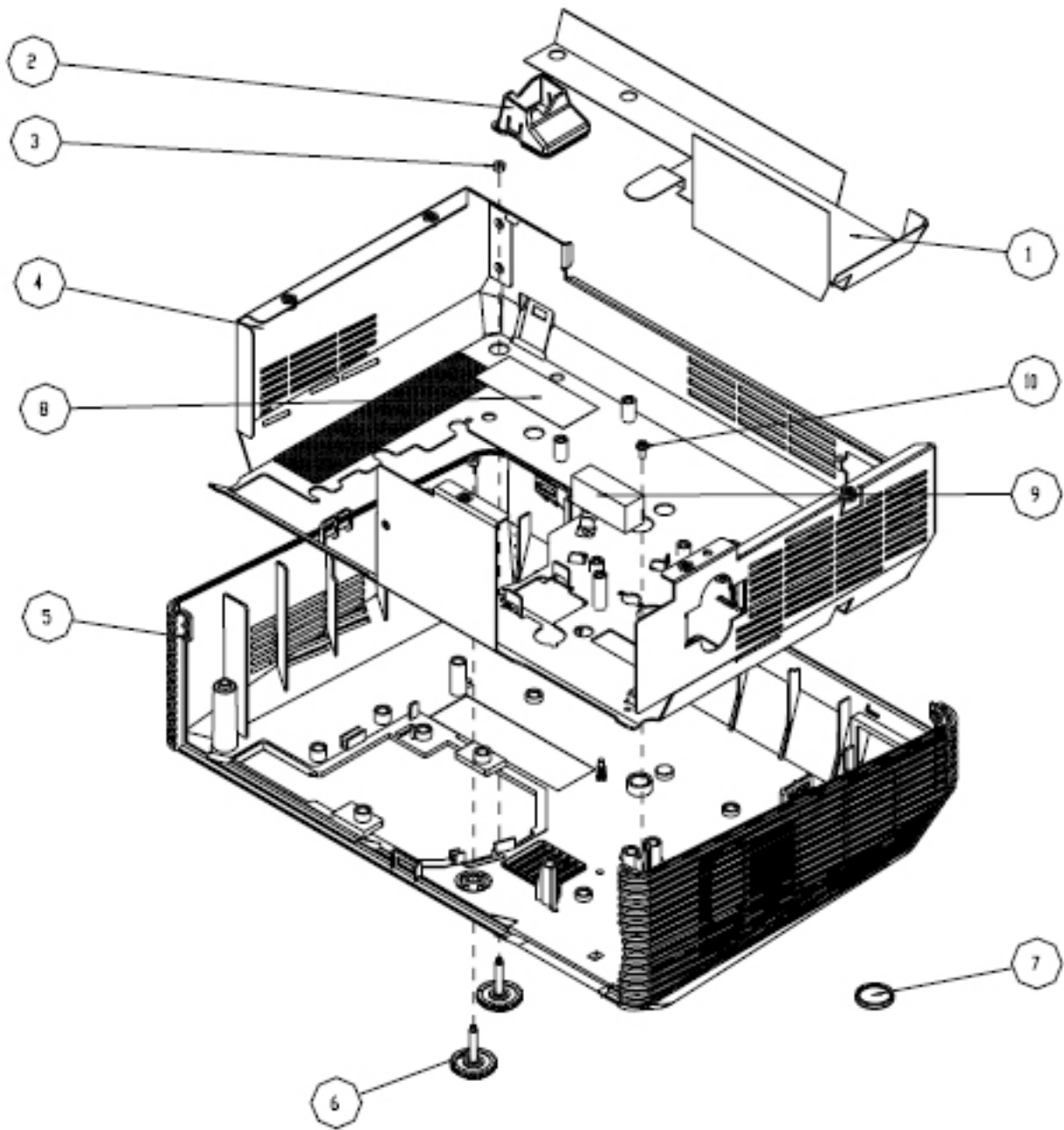

item	P/N	Rev	Description	Parts Supply
1	51.88T10G001	A	MYLAR FOR LVPS X1160	
2	51.88T14G001	A	ROD DUCT X1160	
3	86.00122G015	D1	NUT HEX M2.0*0.4P L15 Ni	
4	61.88T03G001	A	SHIELDING BOTTOM COVER X1160	
5	51.88T02G001	A	BOTTOM COVER X1160	
6	70.83U20G001	A	ASSY ADJUST FOOT MODULE TDP-T9	
7	52.86801G001	A	RUBBER FOOT REAR DP725	
8	41.83C09G001	A	EMI TAPE W20*L50	
9	41.82B01G001	A	EMI GASKET W13*H10.5*L30mm	
10	85.1A123G050	A	SCREW PAN MECH M3*5 Ni	

## D.C. X1160

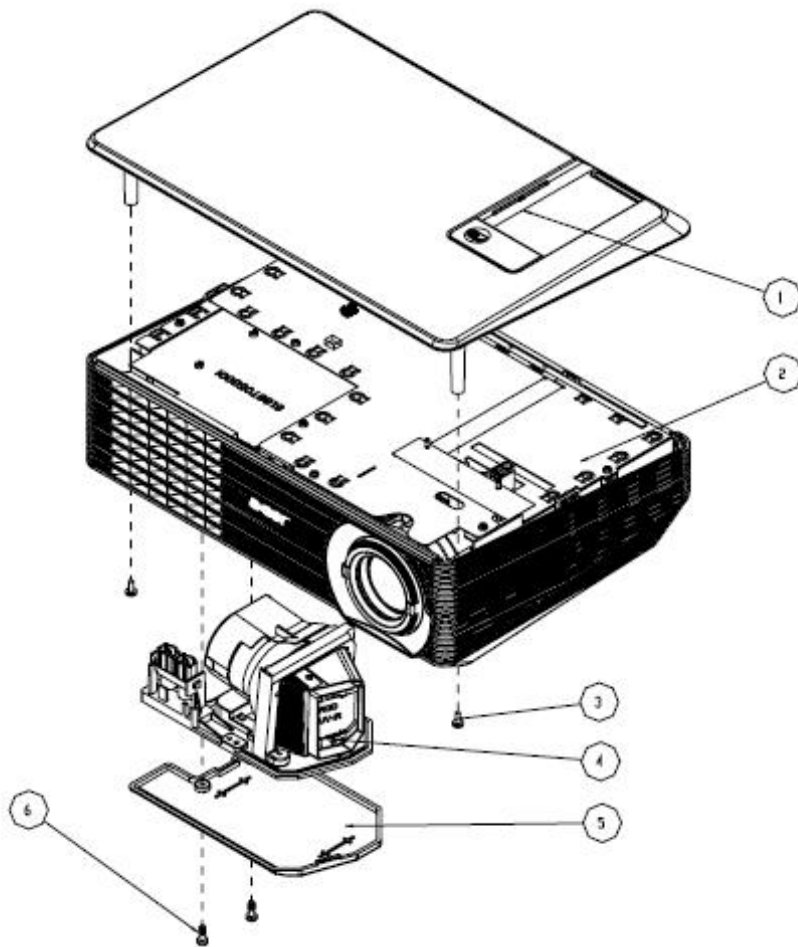

item	P/N	Rev	Description	Parts Supply
1	75.88T03G001	A	ASSY TOP COVER X1160	
2	70.88T01G001	A	ASSY BOTTOM HOUSING MODULE X1160	
3	85.1A323G080	A	SCREW PAN MECH M3*8 BLACK "GREEN"	
4	70.88T02G001	A	ASSY LAMP MODULE X1160	
5	51.88T05G001	A	LAMP COVER X1160	
6	61.00061G001	A	LOCK SCREW PAN MECH M3*8.5-3.5 Ni	

# ASSY BOTTOM HOUSING MODULE X1160

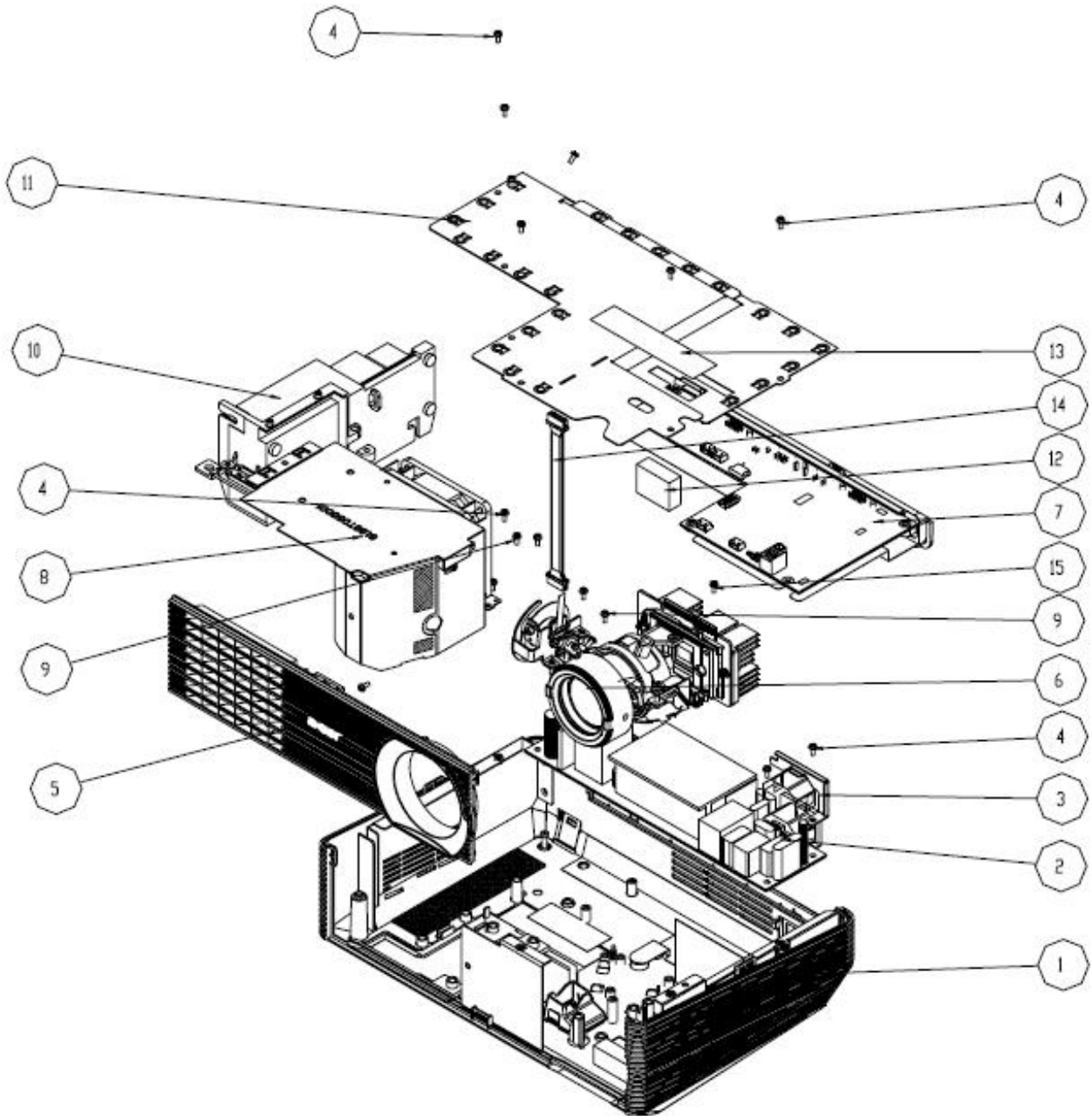

item	P/N	Rev	Description	Parts Supply
1	70.88T09G001	A	ASSY HOUSING MODULE X1160	
2	75.88T01G001	A	ASSY LVPS MATRITEK 160W XD1130	
3	61.88T09G001	A	BRKT INLET X1160	
4	85.1A123G060	A	SCREW PAN MECH M3*6 NI	
5	51.88T03G001	A	FRONT COVER X1160	V
	70.88T12GR01		ASSY ENGINE MODULE X1160(SERVI)	V
6	70.88T05G001	A	ASSY ENGINE MODULE X1160	
7	70.88T03G001	A	ASSYMAIN-BD MODULE X1160	
8	70.88T06G001	A	ASSY FAN SHIELDING X1160	
9	85.1A326G060	A	SCREW PAN HEAD MECH M2.6*6 BLACK	
10	70.88T04G001	A	ASSY LAMP DRIVER MODULE X1160	
11	61.88T02G001	A	SHIELDING TOP COVET X1160	
12	41.85A01G001	A	EMI GASKET / 10*27*20	
13	41.88T01G001	A	EMI q L85*W20	
14	42.00454G001	A	W.A 8P 120mm MB TO LVPS X1160	
15	85.1C224G050	A	SCREW PAN MECH M4*5 COLOR W/TOOTH WASHER	

# ASSY LAMP DRIVER MODULE X1160

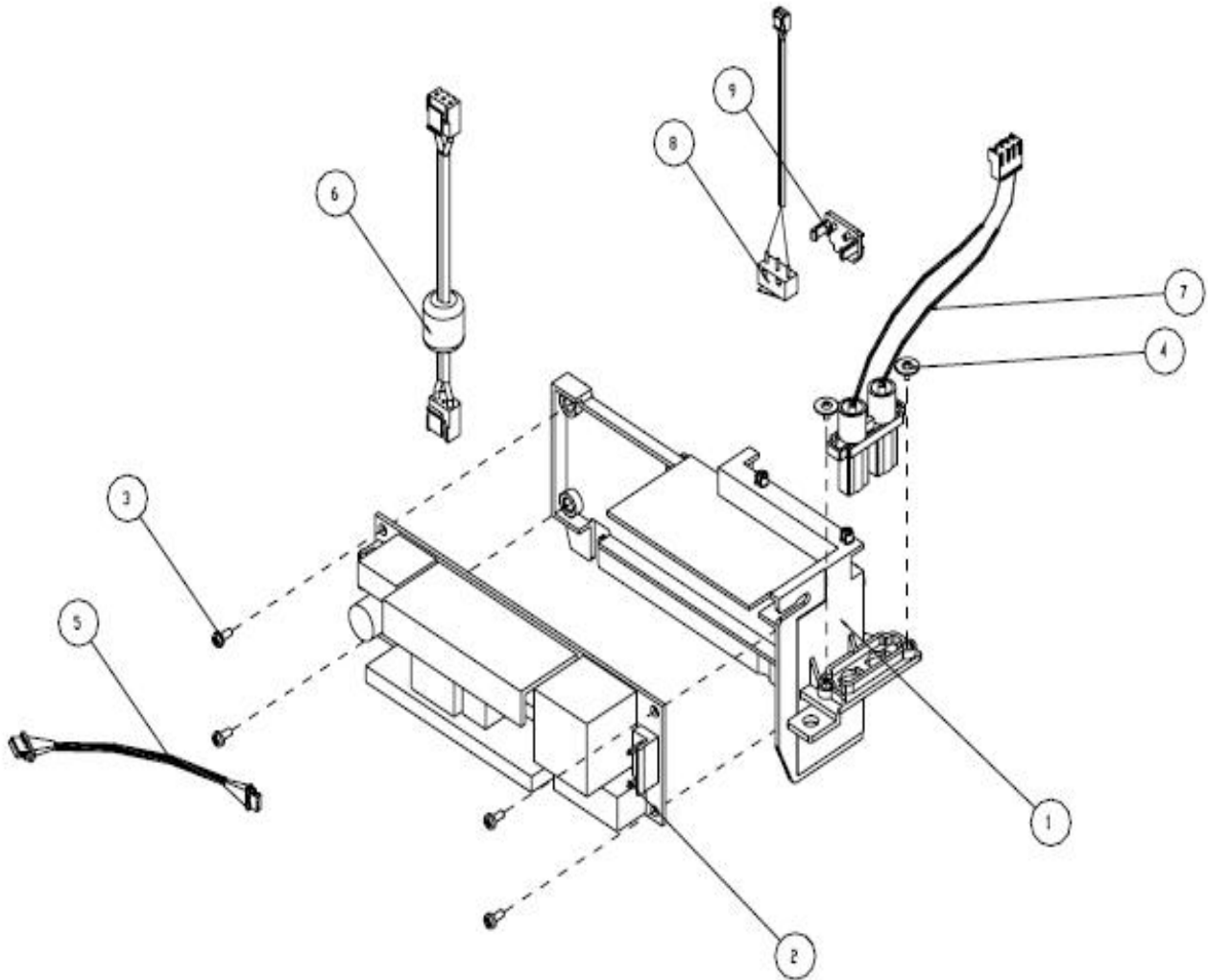



item	P/N	Rev	Description	Parts Supply
1	51.88T11G001	A	HOLDER LAMP DRIVER X1160	
2	75.88T02G001	A	ASSY OSRAM LAMP DRIVER 160W(O6 MIC)	
3	85.1A123G060	A	SCREW PAN MECH M3*6 NI	
4	85.3A122G040	A	SCREW CAP MECH M2*4 Ni	
5	42.00422G001	A	W.A 5P 150mm LAMP DRIVER TO MB X1160	V
6	42.81G01G001	A	CABLE W.A. 2P #20 160mm LAPS TO BALLAST PD120	V
7	42.85F01G001	A	CABLE W.A. 2P #22 160mm LAMP DRIVER TO LAMP EP1690	
8	75.88T05G001	A	ASSY INTERRUPT SWITCH MODULE XD1130	V
9	51.88N25G001	A	INTERLOCK SWITCH HOLDER PC MN3600H,EP721	

# ASSY FAN SHIELDING X1160

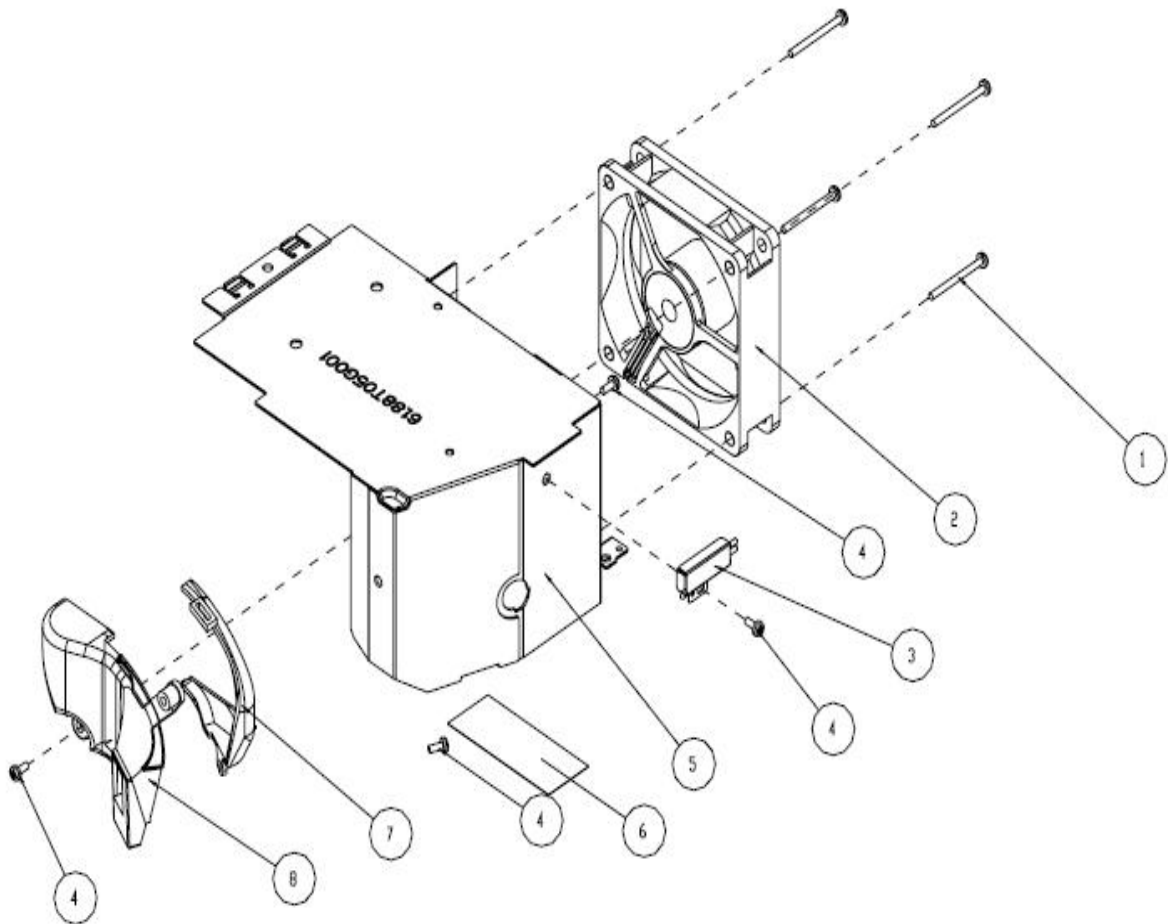

item	P/N	Rev	Description	Parts Supply
1	85.1F123G260	A	SCREW PAN MECH E/SF M3*26 Ni	
2	49.88T01G001	A	SUNON, KDE1207PKV1-A 70*70*20mm AXIAL FAN	
3	43.88T01G001	A	THERMAL SWITCH WITH BRACKET	
4	85.1A123G060	A	SCREW PAN MECH M3*6 NI	
5	61.88T05G001	A	SHIELDING ONE FAN X1160	
6	41.83C09G001	A	EMI TAPE W20*L50	
7	51.88T13G001	A	CAP ONE FAN DUCT X1160	
8	61.88T12G001	A	BODY ONE FAN DUCT X1160	

# ASSY COLOR WHEEL MODULE X1160

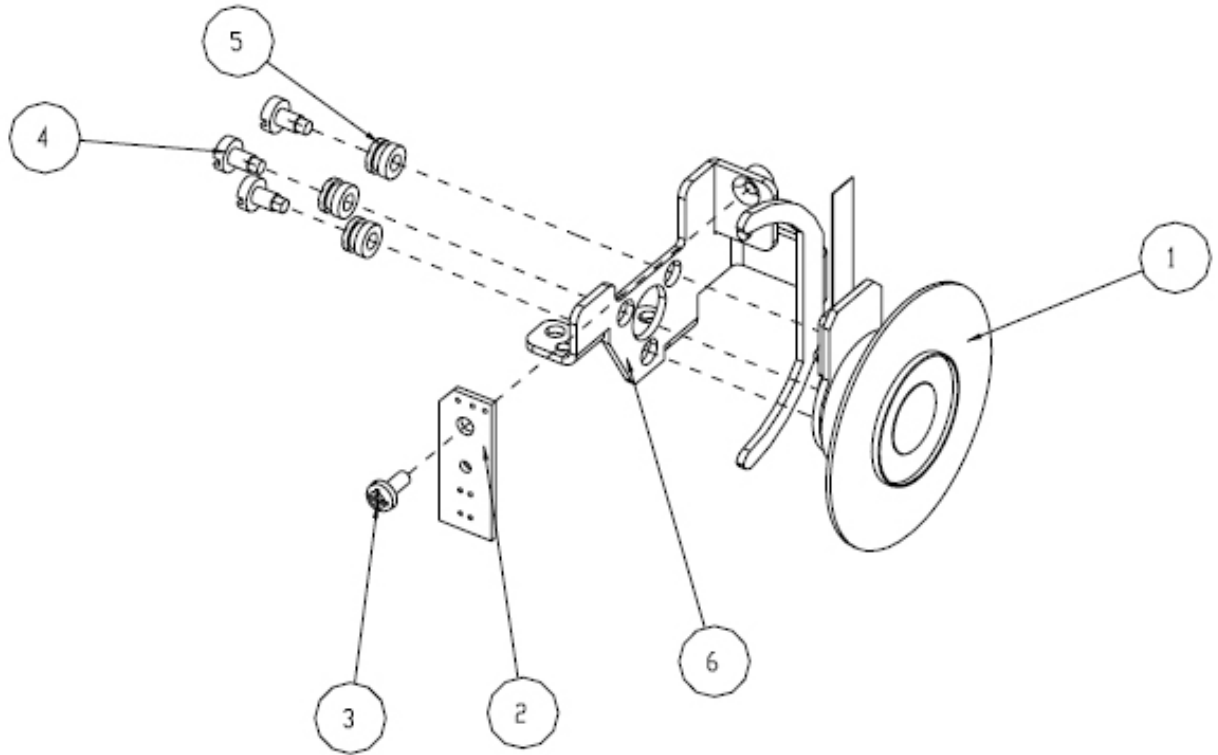

item	P/N	Rev	Description	Parts Supply
1	23.88T19G001	A	YO NA32R CW R90Y28G90C28W42B82 FOR X15	
2	80.87Y04G001	A	PCBA PHOTO SENSOR BOARD FOR PD7280	V
3	85.1A126G040	A	SCREW PAN MECH M2.6*4 Ni	
4	61.83628G001	A	COLOR WHEEL SHOULDER SCREW,EzPro755	
5	52.83615G001	A	COLOR WHEEL DISC RUBBER, EzPro755	
6	61.88N10G001	A	COLOR WHEEL HOLDER SECC,X15	

## ASSY MAIN-BD MODULE X1260

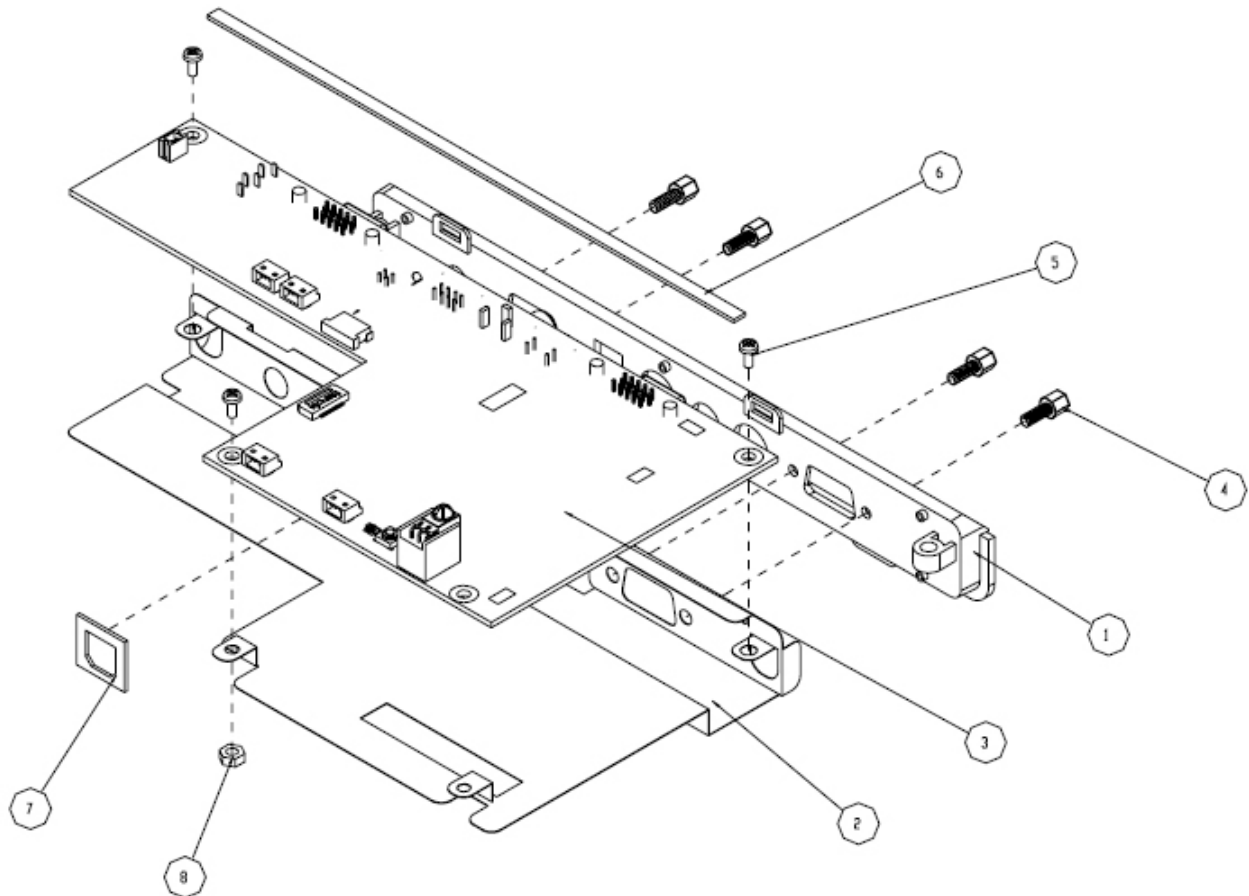

item	P/N	Rev	Description	Parts Supply
1	51.88T04G001	A	IO COVER X1160	
2	61.88T16G001	A	SHIELDING MAIN-BD X1160	
	70.88T33GR01		ASSY MAIN BOARD MODULE X1160	V
3	80.89B01G001	A03	PCBA MAIN BOARD FOR X1260	
4	85.005AGG075	A	SCREW HEX I/O #4-40*H5*L7.5 Ni NYLOK	
5	85.1A123G060	A	SCREW PAN MECH M3*6 NI	
6	41.88T02G001	A	EMI GASKET L180*W4*H1	
7	41.82G03G001	A	EMI GASKET USB CONNECTOR EP719	
8	86.0A123G024	A	HEX NUT M3*0.5P L2.4 Ni	

# ASSY ENGINE MODULE X1260

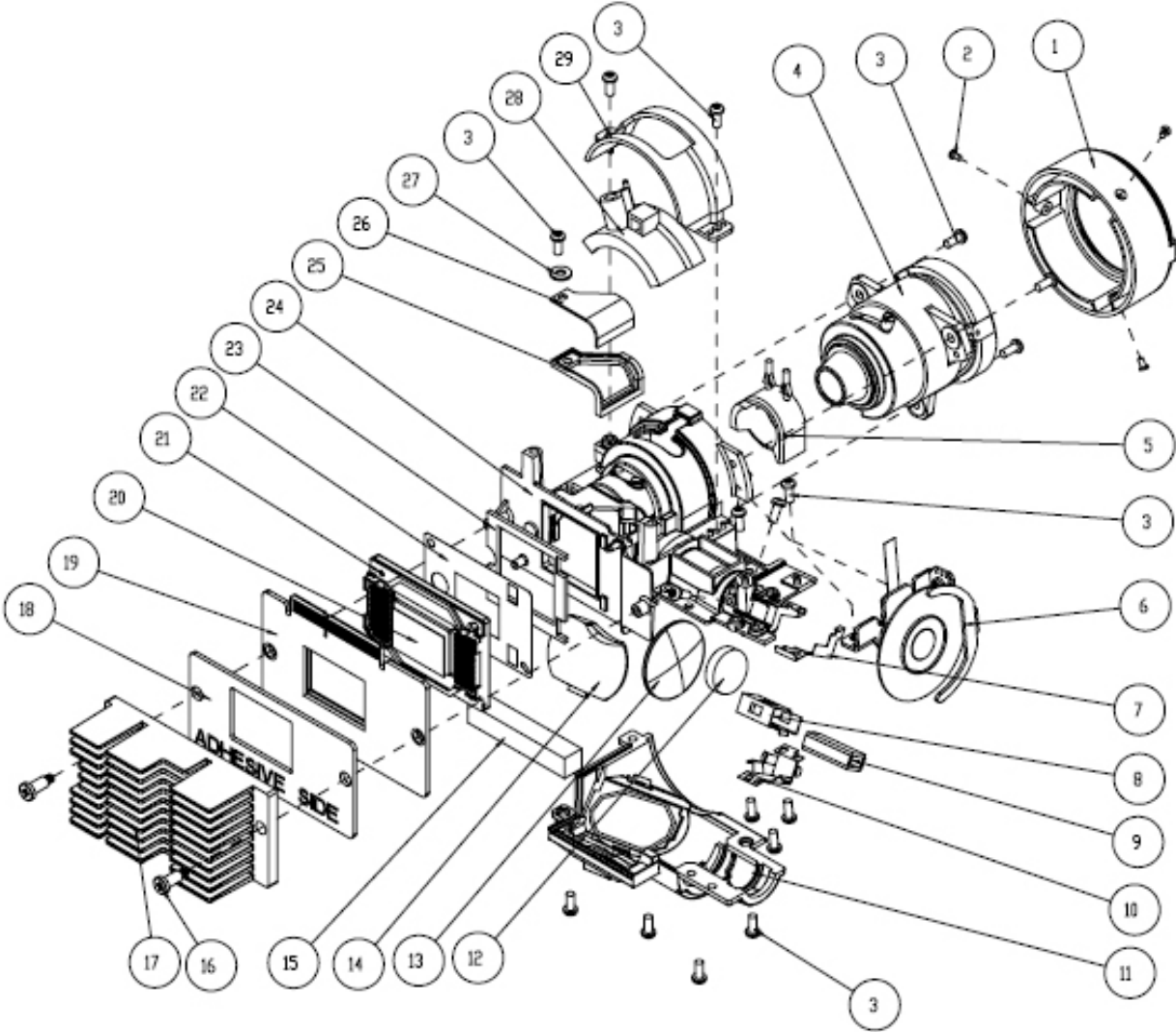

item	P/N	Rev	Description	Parts Supply
1	51.88T09G001	A	FOCUS RING X1160	V
2	85.WA321G050	A	SCREW PAN HEAD M1.7*5 BLACK "	
3	85.1A126G060	A	SCREW PAN MECH M2.6*6 Ni	
4	23.88N01G001	A	YO PROJECTION LENS YM09X FOR X15	
5	52.89F01G001	A	PROJECTION LENS RUBBER HD65	
	70.88T11GR01		ASSY COLOR WHEEL MODULE X1160(SERVICE)	V
6	70.88T08G001	A	ASSY COLOR WHEEL MODULE X1160	
7	61.88N13G001	A	ROD COVER SUS301,X15	
8	61.88N14G001	A	ROD HOLDER SUS301,X15	
9	23.88N17G001	A	YO INTEGRATING ROD FOR x15	
10	61.88N12G001	A	ROD SPRING SUS301,X15	
11	70.88T07G001	A	ASSY ENGINE BOTTOM MODULE X1160	
12	23.88N20G001	A	YO CONDENSER1 FOR X15	
13	23.88N20G011	A	YO CONDENSER2 FOR X15	
14	23.88N06G002	A	PRODISC X15 PLASTIC RELAY LENS	
15	41.85W05G001	A	EMI GASKET W8*H8*L45	
16	85.4A826G118	A	STEP SCREW FOR TYPEX DMD M2.6*11.8mm,X15	
17	61.88N03G001	A	DMD HEAT SINK AL1070,X15	
18	52.88N03G001	A	HEAT SINK RUBBER,X15	
19	80.88T02G001	A03	PCBA DMD BOARD FOR XD1130	V
20	52.87J01G001	A	DMD THERMAL PAD 25*17*0.5t FUJIPOLY SARGON GR-Hn	V
21	48.87M01G001	A	DMD Type-X 1024x768 PIXEL 0.55" XGA LVDS "TI"	
22	61.88N15G001	A	DMD MASK SUS301,X15	
23	52.88N04G001	A	DMD RUBBER,X15	
24	61.88N01G001	A	ENGINE BASE MG,X15	
25	52.88N01G001	A	OFF RAY RUBBER,X15	
26	61.88N05G001	A	OFF RAY PLATE AL5052,X15	
27	87.FL030G008	A	WASHER FLAT 7*3.1*0.8t PC PINGOOD WS-1M	
28	51.89B04G001	A	ZOOM RING X1260	
29	51.89B01G001	A	HOLDER ZOOM RING X1260	



## D.C. X1260

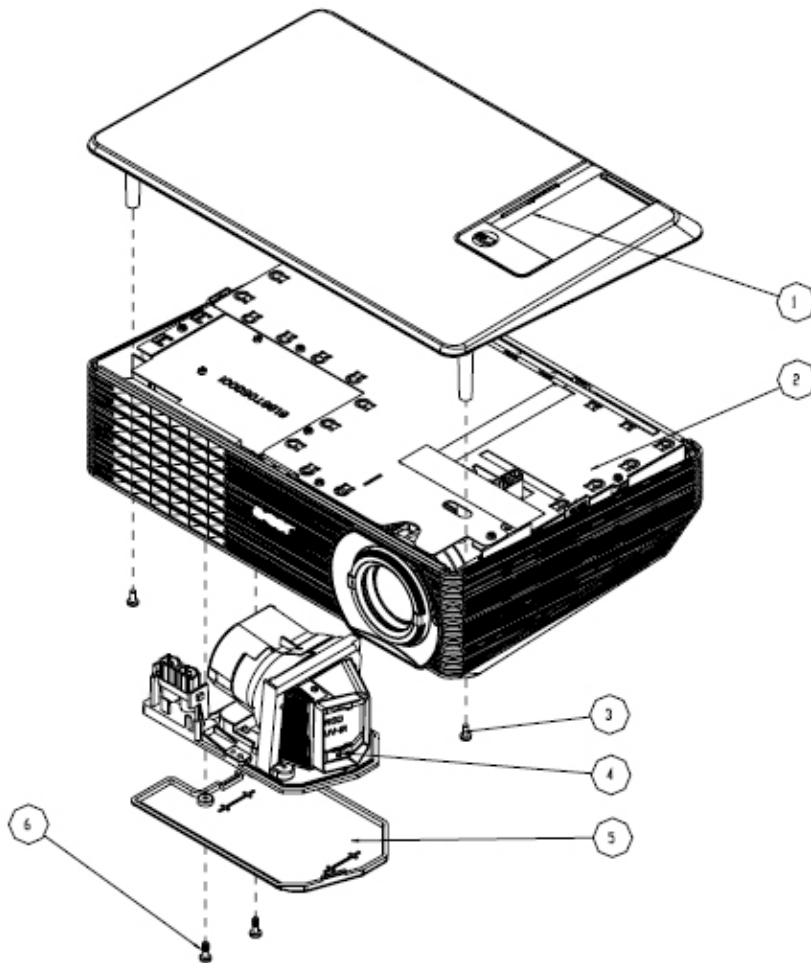

item	P/N	Rev	Description	Parts Supply
1	75.88T03G001	A	ASSY TOP COVER X1160	V
2	70.89B04G001	A	ASSY BOTTOM HOUSING MODULE X1260	
3	85.1A323G080	A	SCREW PAN MECH M3*8 BLACK "GREEN"	
4	70.88T02G001	A	ASSY LAMP MODULE X1160	
5	51.88T05G001	A	LAMP COVER X1160	
6	61.00061G001	A	LOCK SCREW PAN MECH M3*8.5-3.5 Ni	

# ASSY BOTTOM HOUSING MODULE X1260

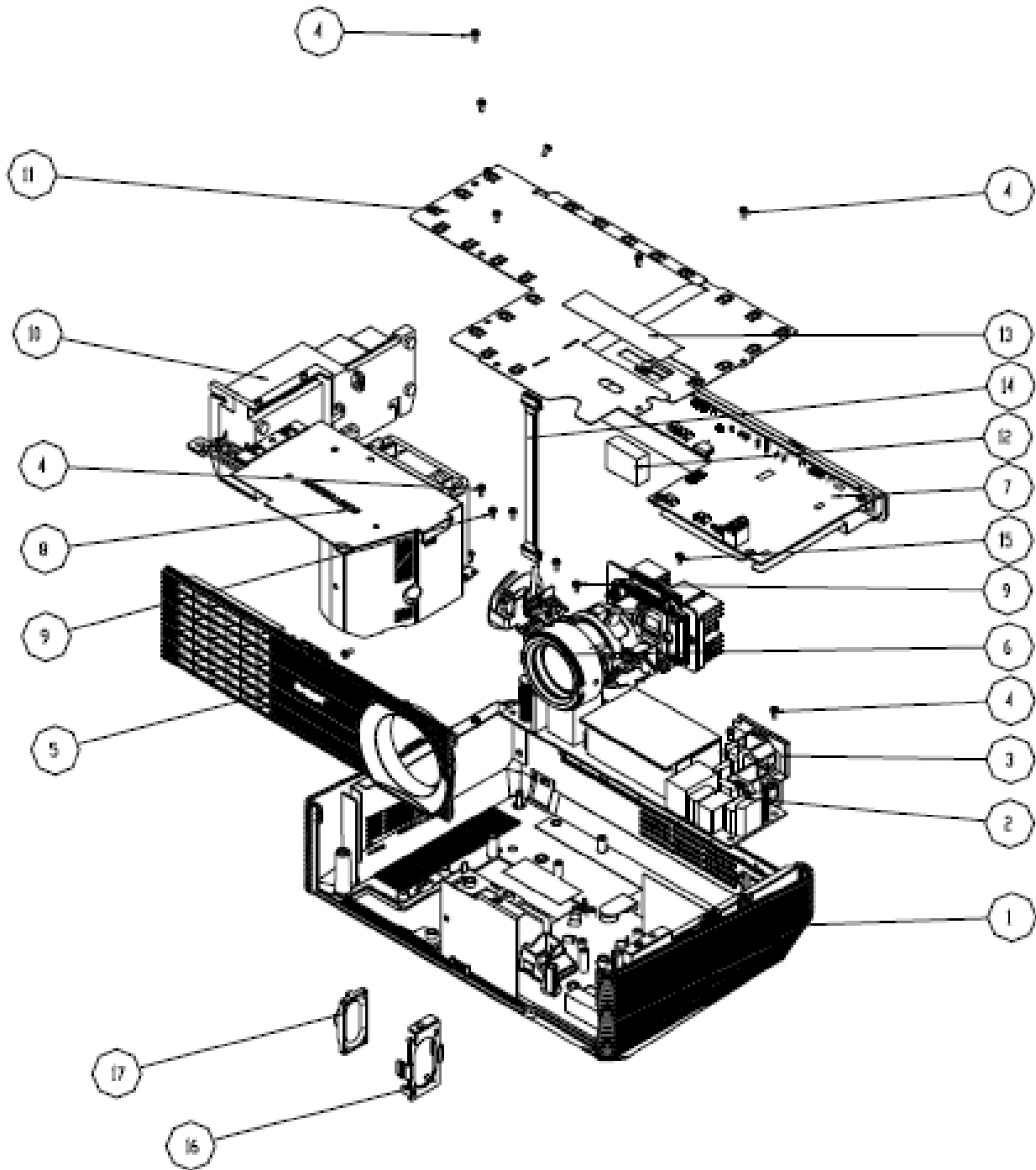

item	P/N	Rev	Description	Parts Supply
1	70.88T09G001	A	ASSY HOUSING MODULE X1160	
2	75.88T01G001	A	ASSY LVPS MATRITEK 160W XD1130	V
3	61.88T09G001	A	BRKT INLET X1160	
4	85.1A123G060	A	SCREW PAN MECH M3*6 NI	
5	75.89B01G001	A	ASSY FRONT COVER X1260	
6	70.89B01G001	A	ASSY ENGINE MODULE X1260	
7	70.89B06G001	A	ASSYMAIN-BD MODULE X1260	
8	70.88T06G001	A	ASSY FAN SHIELDING X1160	
9	85.1A326G060	A	SCREW PAN HEAD MECH M2.6*6 BLACK	
	70.88T22GR01		ASSY LAMP DRIVER MODULE X1160Z	V
10	70.88T04G001	A	ASSY LAMP DRIVER MODULE X1160	
11	61.88T02G001	A	SHIELDING TOP COVET X1160	
12	41.85A01G001	A	EMI GASKET / 10*27*20	
13	41.88T01G001	A	EMI q L85*W20	
14	42.00454G001	A	W.A 8P 120mm MB TO LVPS X1160	V
15	85.1C224G050	A	SCREW PAN MECH M4*5 COLOR W/TOOTH WASHER	
16	51.89B05G001	A	EMI q L85*W20	
17	49.80J01G001	A	SPEAKER,3W,80HM,NEOSONICA,DAB128,200mm,VULCAN-1	

---

# Appendix B

---

## I. Serial Number System Definition

(For non-refresh models, take X1260 for example)

Serial Number Format for Projector

**EYJ5901001    742    00000    59    10**

①                      ②                      ③                      ④                      ⑤

① : EYJ5901001 = Part Number excluded “dot”

② : 742 = Week Code(ex:2007 = 7, forty-two weeks of the year = 42)

③ : 00000 = Serial Numbers

④ : 59 = Manufacturing Code

⑤ : 10 = Projector Version

EX: EYJ5901001742000005910

This label represents the serial number for X1260. It is produced for Europe at CPC on forty-two week of 2007. Its serial code is 00000.

# I.Serial Number System Definition

(For refresh models,take X1260 Refresh for example)

Serial Number Format for Projector

**EYJ7201007    819    00000    59    2    1**

①                      ②                      ③                      ④                      ⑤                      ⑥

① : EYJ7201007= Part Number excluded “dot”

② : 819 = Week Code(ex:2008 = 8,nineteen weeks of the year = 19)

③ : 00000 = Serial Numbers

④ : 59 = Manufacturing Code

⑤ : 2 = Projector Version

⑥ : 1 = Default Language Information

EX: EYJ7201007819000005921

This label represents the serial number for X1260 refresh. It is produced for Europe at CPC on nineteen week of 2008. Its serial code is 00000.

*Note: About the discrimination between refresh model and non refresh model, please refer to RM-P-A08015.*

## II. PCBA Code Definition

PCBA Code for Projector

A   B   XXX   XXXXXXXXXX   CC   XXX   EEEE

①   ②   ③   ④   ⑤   ⑥   ⑦

① : ID

② : Vendor Code

③ : Firmware Version

④ : P/N

⑤ : Revision

⑥ : Date Code

⑦ : S/N

---

# Appendix C

---

## RS232 function command summary table (for X1260/ X1260 Refresh/X1260K Refresh)

General command type (Projector “receives” commands)

	Code (character)	Function feature
1	OKOKOKOKOK	Power On
2	* 0 IR 001	Power On
3	* 0 IR 002	Power Off
4	* 0 IR 004	Keystone
5	* 0 IR 006	Mute
6	* 0 IR 007	Freeze
7	* 0 IR 008	Menu
8	* 0 IR 009	Up
9	* 0 IR 010	Down
10	* 0 IR 011	Right
11	* 0 IR 012	Left
12	* 0 IR 014	Re-Sync
13	* 0 IR 015	Source Analog RGB for D-sub
14	* 0 IR 018	Source S-Video
15	* 0 IR 019	Source Composite Video
16	* 0 IR 020	Source Component Video
17	* 0 IR 021	Aspect ratio 16: 9
18	* 0 IR 022	Aspect ratio 4: 3
19	* 0 IR 023	Volume +
20	* 0 IR 024	Volume –
21	* 0 IR 025	Brightness
22	* 0 IR 026	Contrast
23	* 0 IR 027	Color Temperature
24	* 0 IR 030	Hide

	Code (character)	Function feature
25	* 0 IR 031	Source
26	* 0 IR 032	Video: Color saturation adjustment
27	* 0 IR 033	Video: Hue adjustment
28	* 0 IR 034	Video: Sharpness adjustment
29	* 0 IR 035	Query Model name
30	* 0 IR 036	Query Native display resolution
31	* 0 IR 037	Query company name
32	* 0 IR 041	Aspect ratio 1:1
33	* 0 IR 042	Keystone Up
34	* 0 IR 043	Keystone Down
35	* 0 IR 046	Zoom
36	* 0 IR 047	e-Key
37	* 0 IR 048	Color RGB (Not supply)
38	* 0 IR 049	Language (Not supply)
39	* 0 IR 050	Source HDMI